

Final

**CARSON CITY AIRPORT AUTHORITY
MEETING AGENDA**

Wednesday, March 18, 2026 – 5:30 P.M.

Public Meeting at:

**CARSON CITY COMMUNITY CENTER
(Robert Crowell Board Room)
851 E. William
Carson City, Nevada**

This Agenda Prepared by Corey Jenkins, Airport Manager

- A. CALL TO ORDER, ROLL CALL, AND DETERMINATION OF QUORUM.
- B. PLEDGE OF ALLEGIANCE
- C. APPROVAL OF THE MINUTES OF PAST MEETINGS OF THE AIRPORT AUTHORITY.
- D. MODIFICATION OF THE AGENDA. *The Chairman reserves the right to modify the agenda in order to most effectively process the agenda items. Items may be taken out of order; Items may be combined for consideration by the Authority; Items may be pulled or removed from the agenda at any time.*
- E. PUBLIC COMMENT. Members of the public who wish to address the Airport Authority may speak on *agendized and non-agendized matters* related to the Airport. Comments are limited to three (3) minutes per person or topic. If your item requires extended discussion, please request the Chairman to calendar the matter for a future Airport Authority meeting.
 - 1. The public may provide public comment in advance of a meeting by written submission to the following email address: Manager@flycarsoncity.com. For inclusion or reference in the minutes of the meeting, your public comment must include your full name & address, and be submitted via email by not later than 5:00 P.M. the day before the meeting. The Carson City Airport Authority values your input. Members of the public who wish to provide live public comment may do so during the designated public comment periods, indicated on the agenda in person.

F. AIRPORT ENGINEER'S REPORT (*Non-Action Item*).

G. CONSENT AGENDA

- 1. FOR POSSIBLE ACTION: Approval of Change Order 5 to the contract with Houston Smith Construction, Inc. for AIP 44, Snow Removal Equipment Building ("SRE Building") Construction, in an amount not to exceed \$3,617.90.

Staff Summary: On September 20, 2023, the CCAA approved the award and execution of the construction contract for the SRE Building under AIP 44 to Houston Smith Construction, Inc. in the amount of \$1,548,781.57. Following site coordination and design finalization, the City is requiring additional changes to meet

Final

City Code requirements. The change order is now proposed in the amount of \$3,617.90 for earthwork preparation and concrete for the fire hydrant pad.

2. FOR POSSIBLE ACTION: Approve an improvement permit request for Verizon Wireless for the addition of two new microwave dishes on the roof of the existing Verizon Wireless shelter.

Staff Summary: Verizon would like to install new equipment on the building under the tower. This does not require any amendment to the lease or an airspace analysis.

H. PUBLIC HEARINGS

1. FOR DISCUSSION AND POSSIBLE ACTION: Review and Approve the FY 2026/2027 Preliminary Budget for submission to the Nevada Department of Taxation (C. Jenkins, J. Sutton).

Staff Summary: This is the review of the FY 2026/2027 Preliminary Budget. NRS statutes require that a preliminary budget must be approved and submitted to the Nevada Department of Taxation no later than April 15, 2026.

2. FOR DISCUSSION: Consideration of a pay increase for Airport Manager. (S. Tackes)

Staff Summary: Annual review of Airport Manager. Per Staff/Airport Counsel evaluation, an increase in the Manager's salary is warranted based on a review of comparable regional salaries, the Airport Manager's performance this past year, and increased demands on him from the increase in airport projects.

I. AIRPORT MANAGER'S REPORT (*Non-Action Item*).

J. LEGAL COUNSEL'S REPORT (*Non-Action Item*).

K. TREASURER'S REPORT (*Non-Action Item*).

L. REPORT FROM AUTHORITY MEMBERS (*Non-Action Item*).

1. Status review of projects
2. Internal communications and administrative matters
3. Correspondence to the Authority
4. Status reports and comments from the members of the Authority

M. PUBLIC COMMENT. Members of the public who wish to address the Airport Authority may speak about items discussed on the agenda related to the Airport. Comments are limited to three (3) minutes per person or topic. If your item requires extended discussion, please request the Chairman to calendar the matter for a future Airport Authority meeting.

N. AGENDA ITEMS FOR THE NEXT REGULAR MEETING (*Non-Action Item*).

O. ACTION ON ADJOURNMENT.

Final

* * * * *

DELIVERED (via E-Mail) to the FOLLOWING LOCATIONS for POSTING by 9am, February 13, 2025

The Carson City Airport Website	https://flycarsoncity.com/
State of Nevada Public Notice Website	https://notice.nv.gov
Airport Terminal Building	2600 College Parkway Carson City, NV
Mountain West Aviation	2101 Arrowhead Dr. Carson City, NV
Stellar Aviation of Carson City, LLC	2640 College Parkway Carson City, NV
<i>~ Distribution made to others per request and as noted on the Airport Authority Distribution List ~</i>	
<i>Supporting materials will be posted to the Carson City Airport website www.flycarsoncity.com as available, and can be obtained upon request from the Airport Manager, 2600 E. College Parkway #6, Carson City, NV</i>	

NOTE: The Airport Authority is pleased to make reasonable accommodations for the public who are disabled and wish to attend this meeting. If special arrangements for the meeting are necessary, please notify the Airport Authority at (775) 841-2255 or cjenkins@flycarsoncity.com

Notice: NRS 241.020(3)(b) states that a request for mailed notice of meetings automatically lapses six months after it is made to the public body. A separate written request is not required for each meeting although requests are limited to six months at a time.

THE CARSON CITY AIRPORT AUTHORITY ENCOURAGES WRITTEN COMMENTS FROM THE PUBLIC. Comments should be addressed to the **Airport Manager**, and sent to the following address:

Carson City Airport Authority 2600 E. College Parkway #6, Carson City, Nevada 89706

DRAFT MINUTES
Regular Meeting
Carson City Airport Authority (CCAA)
February 18, 2026 ● 5:30 PM
Community Center Robert “Bob” Crowell Board Room
851 East William Street, Carson City, Nevada

Authority Members

Chair – Tim Puliz	Vice Chair – Harlow Norvell
Treasurer – James Sutton	Member – Michaela Flint
Member – Curtis Horton	Member – Karl Hutter
Member – Bryan Stewart	

Staff

Steve Tackes – Legal Counsel
Corey Jenkins – Airport Manager
Zach Pettit – Public Meetings Clerk

NOTE: A recording of these proceedings, the Board’s agenda materials, and any written comments or documentation provided to the recording secretary during the meeting are public record. These materials are on file in the Clerk-Recorder’s Office, and available for review during regular business hours.

Audio recordings and the meeting minutes of the Carson City Airport Authority meetings are available on <https://www.carson.org/government/city-meetings>.

A. CALL TO ORDER, ROLL CALL, AND DETERMINATION OF QUORUM

(5:34:55) – Chair Puliz called the meeting to order at 5:34 p.m.

(5:35:10) – Roll was called and a quorum was present.

Attendee Name	Status	Arrived
Chair Tim Puliz	Present	
Vice Chair Harlow Norvell	Present	
Treasurer James Sutton	Present	
Member Michaela Flint	Present via WebEx	
Member Curtis Horton	Present	
Member Karl Hutter	Present	
Member Bryan Stewart	Present via Phone	

B. PLEDGE OF ALLEGIANCE

(5:35:45) – Led by Member Horton.

C. APPROVAL OF THE MINUTES OF PAST MEETINGS OF THE AIRPORT AUTHORITY.

(5:36:12) – Chair Puliz introduced the item and entertained comments, changes, and/or a motion to approve the minutes of the December 17, 2025 meeting.

(5:36:25) – MOTION: Treasurer Sutton moved to approve the minutes of the December 17, 2025 meeting. Vice Chair Norvell seconded the motion. The motion carried 7-0-0.

RESULT:	APPROVED (7-0-0)
MOVER:	Sutton
SECONDER:	Norvell
AYES:	Puliz, Norvell, Flint, Horton, Hutter, Stewart, Sutton.
NAYS:	None
ABSTENTIONS	None
ABSENT:	None

D. MODIFICATION OF THE AGENDA.

None.

E. PUBLIC COMMENT

(5:37:02) – Chair Puliz entertained public comments; however, none were forthcoming.

F. AIRPORT ENGINEER’S REPORT

None.

G. CONSENT AGENDA

None.

H. PUBLIC HEARINGS

1. FOR DISCUSSION AND POSSIBLE ACTION: APPROVE REGIONAL EMERGENCY MEDICAL SERVICES AUTHORITY (“REMSA”) AS A CLASS 2 FBO PROVIDING AIR MEDICAL TRANSPORT SERVICE TO CARSON CITY AND SURROUNDING REGION, INCLUDING SERVICES PROVIDED BY THEIR CARE FLIGHT DIVISION AND THEIR PART 135 ENTITY, AIR METHODS CORPORATION, FOR USE BY REMSA.

(5:38:12) – Chair Puliz introduced the item. Mr. Jenkins referenced the Staff Report and Supporting Materials, all of which are incorporated into the record.

(5:44:57) – Mr. Tackes stated that he has reviewed all elements of the application and confirmed that it meets all required criteria. He reported that, upon conferring with the Secretary of State, all interrelated entities listed on the certificate of insurance are current and in good standing. Mr. Tackes noted that he and Mr. Jenkins reviewed REMSA’s financials, which are very strong for a nonprofit organization. The financial statements were not included in the public record, as REMSA is not a publicly reporting company.

(5:45:47) – Treasurer Sutton inquired whether the insurance coverage was sufficient. Mr. Tackes confirmed sufficient insurance coverage, reasoning that a \$1 million per-occurrence policy is lower than what would be required for a full-service Fixed-Base Operator (FBO). He clarified that REMSA is not a full-service FBO and is instead providing an in-and-out service to the community. He added that he reviewed the policy in detail to ensure there were no caveats.

(5:46:42) – Vice Chair Norvell asked whether Stellar Aviation realizes any fuel sales and whether the Airport receives any fuel flowage fees. Mr. Jenkins confirmed that REMSA will purchase fuel from either Stellar Aviation or Mountain West pursuant to its commitment to Stellar’s Spill Prevention, Control, and Countermeasure (SPCC) Plan. He clarified that this does not prevent REMSA from purchasing fuel from any other provider on the airfield. Mr. Jenkins affirmed the fuel flowage fees are passed through the FBO to the Airport.

(5:47:39) – Chair Puliz entertained public comments; however, none were forthcoming.

(5:47:50) – Chair Puliz stated that he has relationships with several leaders within the organization and holds them in high regard. He expressed confidence in both leadership and the application.

(5:48:22) – Vice Chair Norvell expressed his support and excitement to see REMSA utilize the Airport and provide services to the community. He also cautioned REMSA to remain aware of fixed-wing airplanes.

(5:48:47) – MOTION: Vice Chair Norvell moved to approve the Class II FBO Permit Application for REMSA, including services provided by their Care Flight division and their Part 135 entity, Air Methods Corporation, for use by REMSA. Member Hutter seconded. The motion carried 7-0-0.

RESULT:	APPROVED (7-0-0)
MOVER:	Norvell
SECONDER:	Hutter
AYES:	Puliz, Norvell, Flint, Horton, Hutter, Stewart, Sutton
NAYS:	None
ABSTENTIONS	None
ABSENT:	None

I. AIRPORT MANAGER’S REPORT

(5:49:23) – Chair Puliz introduced the item. Mr. Jenkins referenced the Airport Manager’s Report, which is incorporated into the record. He stated that the primary activity this month was the Airport Capital Improvement Plan (ACIP) meeting with the FAA. Discussion focused on funding availability for the runway extension versus required pavement reconstruction, as much of the pavement is nearing a Pavement Condition Index of 55. He informed the FAA that while the Airport can self-fund pavement rehabilitation, it cannot self-fund full reconstruction and emphasized the need for FAA support to avoid delaying the runway extension. He reported that the FAA provided positive feedback and remains supportive of the extension.

(5:51:54) – Mr. Jenkins reported that staff has been actively working on development of the upcoming fiscal year budget.

(5:52:08) – Mr. Jenkins stated that developer interest in new hangar construction remains high. One site plan was submitted but was incompatible with airport requirements; feedback was provided, and a revised submittal is expected.

(5:52:50) – Mr. Jenkins noted an increase in noise complaints from a small number of individuals. One low-flying helicopter concern was valid and addressed with the pilot; other complaints showed no violations of noise abatement procedures. All complaints continue to be investigated thoroughly.

(5:54:38) – Mr. Jenkins reported that construction of the SRE Building continues, though some delays have occurred. A small change order is anticipated and may appear on the next agenda.

(5:55:55) – Mr. Jenkins stated that he will be attending the Government Issues Conference in Washington, D.C., and the Western Nevada Development District (NWDD) Annual Conference, noting the importance of continued advocacy for runway extensions and engagement with non-aviation community partners.

(5:58:20) – Mr. Jenkins reported continued trends of increased fuel sales and slightly reduced overall operations, consistent with greater jet and turboprop activity. He added that winter mowing was completed in additional areas due to mild weather, supporting wildlife mitigation efforts.

(6:00:08) – Vice Chair Norvell requested an update regarding night approval of the RNAV (GPS) RWY 27 approach. Mr. Jenkins stated that there have been no updates since the last meeting and that the project remains in the FAA queue.

J. LEGAL COUNSEL’S REPORT

(6:02:13) – Chair Puliz introduced the item. Mr. Tackes noted that he had nothing to report.

K. TREASURER’S REPORT

(6:02:18) – Chair Puliz introduced the item. Treasurer Sutton noted that he and Mr. Jenkins have been crunching some numbers but that everything remains preliminary at this point. He stated that the budget will be ready for review in March.

L. REPORT FROM AUTHORITY MEMBERS

1. STATUS REVIEW OF PROJECTS

2. INTERNAL COMMUNICATIONS AND ADMINISTRATIVE MATTERS

3. CORRESPONDENCE TO THE AUTHORITY

4. STATUS REPORTS AND COMMENTS FROM THE MEMBERS OF THE AUTHORITY

None.

M. PUBLIC COMMENT

(6:03:02) – Chair Puliz entertained public comments; however, none were forthcoming.

N. AGENDA ITEMS FOR THE NEXT REGULAR MEETING

O. ACTION ON ADJOURNMENT

(6:03:21) – MOTION: Chair Puliz adjourned the meeting at 6:03 p.m.

The Minutes of the February 18, 2026 Carson City Airport Authority meeting are so approved this 18th day of March 2026.



Engineer's Report

WOOD RODGERS
BUILDING RELATIONSHIPS ONE PROJECT AT A TIME

To: Carson City Airport Authority
From: Brian Martinezmoles **CC:** Mr. Corey Jenkins, Airport Manager
Date: March 16, 2026
Subject: Engineer's Report for Carson City Airport Authority Board Meeting

Please find below a status report of the projects and/or tasks Wood Rodgers is currently engaged in on behalf of the Carson City Airport.

1.0. RSA Drainage & Improvements Project

The project is currently under design proceeding toward 90% Design level and 60% plans were provided to the FAA last month.

2.0. Main Apron Rehabilitation Project / 2025 Pavement Preservation

This project is scheduled to be advertised to bid next week and will be advertised on NGEM thanks to support and collaboration from Carson City staff.

3.0 Airport Capital Improvement Plan (ACIP)

Wood Rodgers in addition to the Airport Manager and Airport Planner (Coffman) held a meeting with the FAA on 2/17/26 to discuss the 2027-2030 ACIP. The ACIP, previously approved by the CCAA Board is scheduled for hearing/approval with the Carson City Board of Supervisors this month.



FlyCarsonCity.com

CCAA BOARD MEMO

Agenda Item: G-1

BOARD MEMO 2026-02

Meeting Date: March 18, 2026

Agenda Title: FOR POSSIBLE ACTION: Approval of Change Order 5 to the contract with Houston Smith Construction, Inc. for AIP 44, Snow Removal Equipment Building (“SRE Building”) Construction, in an amount not to exceed \$3,617.90.

Staff Summary: On September 20, 2023, the CCAA approved the award and execution of the construction contract for the SRE Building under AIP 44 to Houston Smith Construction, Inc. in the amount of \$1,548,781.57. Following site coordination and design finalization, the City is requiring additional changes to meet City Code requirements. The change order is now proposed in the amount of \$3,617.90 for earthwork preparation and concrete for the fire hydrant pad.

Agenda Action: Motion and Approval

Time Requested: 0 Minutes

Proposed Motion

I move to approve Change Order 5 for \$3,617.90

CCAA’S Strategic Goal

Maintain financial stability and support economic activity in the region.

Previous Action and Executive Summary

September 20, 2023 (Item G-2) – CCAA executed the construction contract for the SRE Building to Houston Smith Construction.

June 18, 2025 (Item H-2) – CCAA approved Change Order 1 for an additional access road and inflation related cost increases of \$47,475.

October 15, 2025 (Item H-3) – CCAA approved Change Order 2 for \$6,152.50 and Change Order 3 for \$36,317.53.

December 17, 2025 (Item G-2) – CCAA approved Change Order 4 for swale landscaping and check valve installation for \$31,278.85

Financial Information

Is there a fiscal impact?

No X Yes

If yes, account name/number & amount:

CCAA 3099 General Fund / Total: \$3,617.90

Is it currently budgeted?

No

Alternatives

N/A

Board Action Taken:

Motion: _____

1) _____

2) _____

Aye/Nay

(Vote Recorded)

CONTRACT CHANGE ORDER NO. 5

AIRPORT: Carson City Airport

DATE: February 13, 2026

LOCATION: Carson City, Nevada

AIP NO.: 3-32-0004-044-2023

CONTRACTOR: Houston Smith Construction, Inc.

You are requested to perform the following described Work upon receipt of an approved copy of this document or as directed by the Engineer:

ITEM NO.	DESCRIPTION	UNIT	UNIT PRICE	QUANTITY	AMOUNT
1	Earthwork prep and concrete for fire hydrant pad ¹	LS	\$3,617.90	1	\$3,617.90
This Change Order Total			\$3,617.90		
Previous Change Order(s) Total			\$121,223.88		
Original Contract Price			\$1,548,781.57		
Revised Contract Total			\$1,673,623.35		

¹Per Houston Smith Const. Change Order Request #CC-2023-303-7 dated December 23, 2025.

Item No. 1 shall not affect the Contract days total. This document shall become an Amendment to the Contract (Agreement Article 36) and all provisions of the Contract will apply. Referenced documents are included in the following page(s).

Recommended by: Lochner February 13, 2026
 Engineer Date

Approved by: _____ _____
 Owner Date

Accepted by: _____ _____
 Contractor Date

Approved by: See Page CO-2 _____
 Federal Aviation Administration Date

AIP NO.: 3-32-0004-044-2023

CHANGE ORDER NO. 5

AIRPORT: Carson City Airport

LOCATION: Carson City, Nevada

FAA Concurrence:

- This concurrence is subject to the availability of Federal funds and limitations of the Grant Agreement.
- This concurrence is subject to the availability of Federal funds and limitations of the Grant Agreement and comments in our letter dated _____.
- This concurrence is for record purposes only, with no Federal participation.

By: _____ Date _____
Program Manager, PHX-ADO

NOTE: Change Orders and Supplemental Agreements require FAA approval prior to construction. Otherwise, no Federal participation can be granted.



CO #	DATE
CC-2023-303-7	12/23/2025

Subject: Fire Hydrant Pad
Time Delay: No

BILL TO

Armstrong Consultant
Nadine Burgard
1575 Delucchi Lane
Reno, NV 89502

CUSTOMER

Carson City Airport
Nadine Burgard
2600 East College Parkway
Carson City, NV 89706

PROJECT

Carson City Airport SRE Building
PROJECT #: CC-2023-303
2600 East College Parkway
Carson City, NV 89706

DESCRIPTION
Earthworks and Concrete for the Fire Hydrant

	Qty	Price/Unit	Total
Concrete <i>Concrete Pad Fire hydrant</i>	1	\$1,720.40	\$1,720.40
Earthwork <i>Prep For Hydrant</i>	1	\$1,897.50	\$1,897.50

Subtotal	\$3,617.90
Tax: (0%)	\$0.00
Total	\$3,617.90



CO #	DATE
CC-2023-303-7	12/23/2025

REVISED BALANCE SUMMARY	
Original Contract Amount	\$1,548,781.57
Net Change by Previous Change Orders	\$94,402.87
Contract Amount Prior to this Change	\$1,643,184.44
Amount of this Change Order	\$3,617.90
Revised Contract Amount, Including this Change Order	\$1,646,802.34

APPROVAL
This CO has been accepted on _____ by _____
Signature: _____

PHOTOS



CC_airport_CO_Concrete



Carson_City_SRE_Change_Request_CR-07a_Pad_Prep

Valley Concrete Co., Inc.**CHANGE ORDER**

601 S. 15th St.

Sparks, NV 89431

PH.(775) 329-0656 FAX(775) 329-4159

NV LIC # 8697A &27598 license limit - unlimited

PROPOSAL SUBMITTED TO HOUSTON SMITH	PHONE 775-849-1802	DATE February 5, 2026
ADDRESS 6119 RIDGEVIEW CT. STE. 500	JOB NAME CARSON CITY AIRPORT CONSTRUCT SRE BLDG.	
CITY, STATE AND ZIP CODE RENO, NV. 89519	JOB LOCATION 2600 E. COLLEGE DR. CARSON CITY, NV. 89706	
	fax xaiver@houstonsthinc.com	JOB PHONE

WE HEREBY SUBMIT SPECIFICATIONS AND ESTIMATES FOR **REVISED 2/5/2026**
FORM AND POUR 6' X 6' X 6" HYDRANT PAD.

\$1,496.00

INCLUDES: CONCRETE AND FROST PROTECTION.

We propose hereby to furnish Material and Labor - complete with above specifications, for the sum of:
 As noted above dollars (\$)

Payment to be made as follows: **NET 30 DAYS**

All material is guaranteed to be as specified. All work to be completed in a workmanlike manner according to standard practices.
 Any alteration or deviation from above specifications involving extra costs will be executed only upon written orders, and will become an extra charge over and above the estimate. All agreements contingent upon strikes, accidents or delays beyond our control.
 Owner to carry fire, tornado, and other necessary insurance. Our workers are fully covered by Workman's Compensation Insurance.

Authorized Signature**PROJECT MANAGER/ESTIMATOR: TONYA. BAUER****Note: This proposal may be withdrawn by us if not accepted within 30 days**

Residential Construction Recovery Fund
 Payment may be available from the Recovery Fund if you are damaged financially by a project performed on your residence pursuant to a contract, including, construction, remodeling, repair or other improvements, and the damage resulted from certain specified violations of Nevada law by a contractor licensed in this State. To obtain information relating to the Recovery Fund and filing a claim for recovery from the Recovery Fund, you may contact the State Contractors Board at the following locations:
State Contractors' Board - 9670 Gateway Dr. Ste 100 Reno NV 89521 775-688-1141
State Contractors' Board - 2310 Corporate Circle Ste 200 Henderson NV 89074 702-486-1100

Acceptance of Proposal
 conditions are satisfactory and are hereby accepted. The above prices, specifications and do the work specified. Payment will be made as outlined above.

Signature _____

Date of Acceptance _____ **Signature** _____

SIGN BOTH COPIES AND RETURN 1 COPY



Website: www.acegradingandpaving.com

Dave: 775.742.6521, dave@agpreno.com

Mike: 775.237.9316, mike@agpreno.com

Change Request – CR-07

DATE: February 5, 2026
TO: Houston Smith Construction
ATTN: Xaiver Couch
EMAIL: xaiver@houstonsmithinc.com
PHONE: 702-824-7196
FROM: Mike Protani
RE: Carson City SRE Shed – Fire Hydrant Area Prep

An additional concrete pad with Curb/Gutter will be required following Carson City plan review drawing set. The price below is for excavation, base and grade for concrete.

Item #	Task	Contract Value	Revised Value	CR Value
CR-07	Adder – Prepare Curb/Gutter and Fire Hydrant Pad for Concrete	\$0	\$1,650	\$1,650

Change Request Detail:

	Value
Trucking	\$ 100
Materials	\$ 50
Labor and Equipment	\$ 1,500
Total	\$ 1,650

Please acknowledge acceptance by completing the information below, and e-mailing it back to me at mike@agpreno.com.

Accepted by: _____
 Print Name: _____
 Date: _____



FlyCarsonCity.com

CCAA BOARD MEMO

Agenda Item: G-2

BOARD MEMO 2026-03

Meeting Date: March 18, 2026

Agenda Title: FOR POSSIBLE ACTION: Approve an improvement permit request for Verizon Wireless for the addition of two new microwave dishes on the roof of the existing Verizon Wireless shelter.

Staff Summary: Approve an improvement permit request for Verizon Wireless for the addition of two new microwave dishes on the roof of the existing Verizon Wireless shelter.

Agenda Action: Motion and Approval

Time Requested: 0 Minutes

Proposed Motion

I move to approve the improvement permit request for Verizon Wireless for the addition of two new microwave dishes on the roof of the existing Verizon Wireless shelter

CCAA’S Strategic Goal

Support economic activity in the region.

Previous Action and Executive Summary

August 6, 2009 – Carson City Board of Supervisors executed original Verizon Lease.

September 18, 2019 (Item G-4) – The Carson City Airport Authority approved an amendment.

Financial Information

Is there a fiscal impact?

X No Yes

If yes, account name/number & amount: N/A

Is it currently budgeted?

N/A

Alternatives

Do not approve the improvement permit application.

Board Action Taken:

Motion: _____

1) _____

2) _____

Aye/Nay

(Vote Recorded)



TENANT IMPROVEMENT PERMIT
CARSON CITY AIRPORT AUTHORITY
CARSON CITY AIRPORT

This portion MUST be completed by Tenant

Date: 2/20/2026	Permit No:
Tenant: Verizon Wireless	Project Location: 2600 E College Pkwy
Tenant Contact Name: Jeremy Bubenicek	Phone: (925) 532-3656
	E-mail: jeremy.bubenicek@verizonwireless.com
Architect/Designer/Engineer: Streamline Engineering	Address: 125 Cyber Ct, Rocklin, CA 95765
Anticipated Start Date: 8/3/2026	Anticipated Completion Date: 8/14/2026

Project Description (attach additional information, as necessary):
 Installing (2) new microwave dishes on roof of existing Verizon Wireless shelter. No new ground disturbance or tower work for this scope of work.

CONTRACTOR'S INFORMATION

General: STC NETWORK, INC.	Nevada State Contractor's License #: 89689
Address: 11611 INDUSTRY AVE. FONTANA CA, 92337	Phone: 916-660-1681
	E-mail: ASEMENOFF@CLINELLC.COM
Subcontractor:	Nevada State Contractor's License #:
Address:	Phone:
	E-mail:
Subcontractor:	Nevada State Contractor's License #:
Address:	Phone:
	E-mail:
Tenant's Signature:	Date:
Contractor's Signature:	Date:
Plans and Specifications on file with Airport Manager? <input checked="" type="checkbox"/> Yes <input type="checkbox"/> No	Date:



CARSON CITY AIRPORT (28GHZ P2P-TX/RX)

2600 E COLLEGE PARKWAY, CARSON CITY, NV 89706

MDG LOCATION ID: 5000246353

PROJECT ID#: 17556403

Issued For:

CARSON CITY AIRPORT

2600 E COLLEGE PARKWAY
CARSON CITY, NV 89706

PREPARED FOR



2770 SHADELANDS DR, BLDG 11
WALNUT CREEK, CA 94598

Vendor:



MDG LOCATON ID: 5000246353

PROJECT NO: 17556403

DRAWN BY: J. ZHAR

CHECKED BY: K. SORENSEN

APPROVED BY: J. SPORE

ISSUE STATUS

REV	DATE	DESCRIPTION	CAD
1	02/04/26	CD 100%	A.M.
0	01/28/26	CD 90%	J.Z.

Licensee:

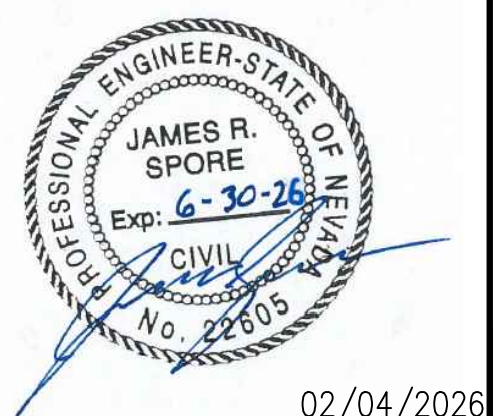

02/04/2026

IT IS A VIOLATION OF LAW FOR ANY PERSON, UNLESS THEY ARE ACTING UNDER THE DIRECTION OF A LICENSED PROFESSIONAL ENGINEER, TO ALTER THIS DOCUMENT.

ENGINEER:



SHEET TITLE:

TITLE SHEET

SHEET NUMBER:

T-1.1

PROJECT DESCRIPTION

A MODIFICATION OF AN (E) VERIZON WIRELESS UNMANNED TELECOMMUNICATION FACILITY CONSISTING OF:

- INSTALLING (2) (N) MICROWAVE DISHES ON (N) MOUNTS ON THE (E) SHELTER ROOFTOP
- INSTALLING (2) (N) ODU UNITS

PROJECT INFORMATION

SITE NAME:	CARSON CITY AIRPORT	APPLICANT:	VERIZON WIRELESS 2770 SHADELANDS DR, BLDG 11 WALNUT CREEK, CA 94598
MDG LOCATION ID:	5000246353	SITE ACQUISITION COMPANY:	EPIC WIRELESS GROUP LLC 605 COOLIDGE DR, SUITE 100 FOLSOM, CA 95630
COUNTY:	CARSON CITY	LEASING CONTACT:	ATTN: KELLEY CERVANTES 916-755-2479 KELLEY.CERVANTES@EPICWIRELESS.NET
JURISDICTION:	CITY OF CARSON CITY	ZONING CONTACT:	ATTN: JOSH JORDAN 916-704-0897 JOSH.JORDAN@EPICWIRELESS.NET
APN:	005-011-01	CONSTRUCTION CONTACT:	ATTN: JOSH JORDAN 916-704-0897 JOSH.JORDAN@EPICWIRELESS.NET
SITE ADDRESS:	2600 E COLLEGE PARKWAY CARSON CITY, NV 89706		
CURRENT ZONING:	-		
CONSTRUCTION TYPE:	II-B		
OCCUPANCY TYPE:	U, (UNMANNED COMMUNICATIONS FACILITY)		
POWER:	NV ENERGY		
TELEPHONE:	AT&T		
LATITUDE:	N 39° 11' 26.7288" NAD 83		
LONGITUDE:	W 119° 44' 24.2196" NAD 83		
PROPERTY/TOWER OWNER:	CARSON CITY AIRPORT AUTHORITY 2600 E GRAVES LANE #6 CARSON CITY, NV 89706		

VICINITY MAP

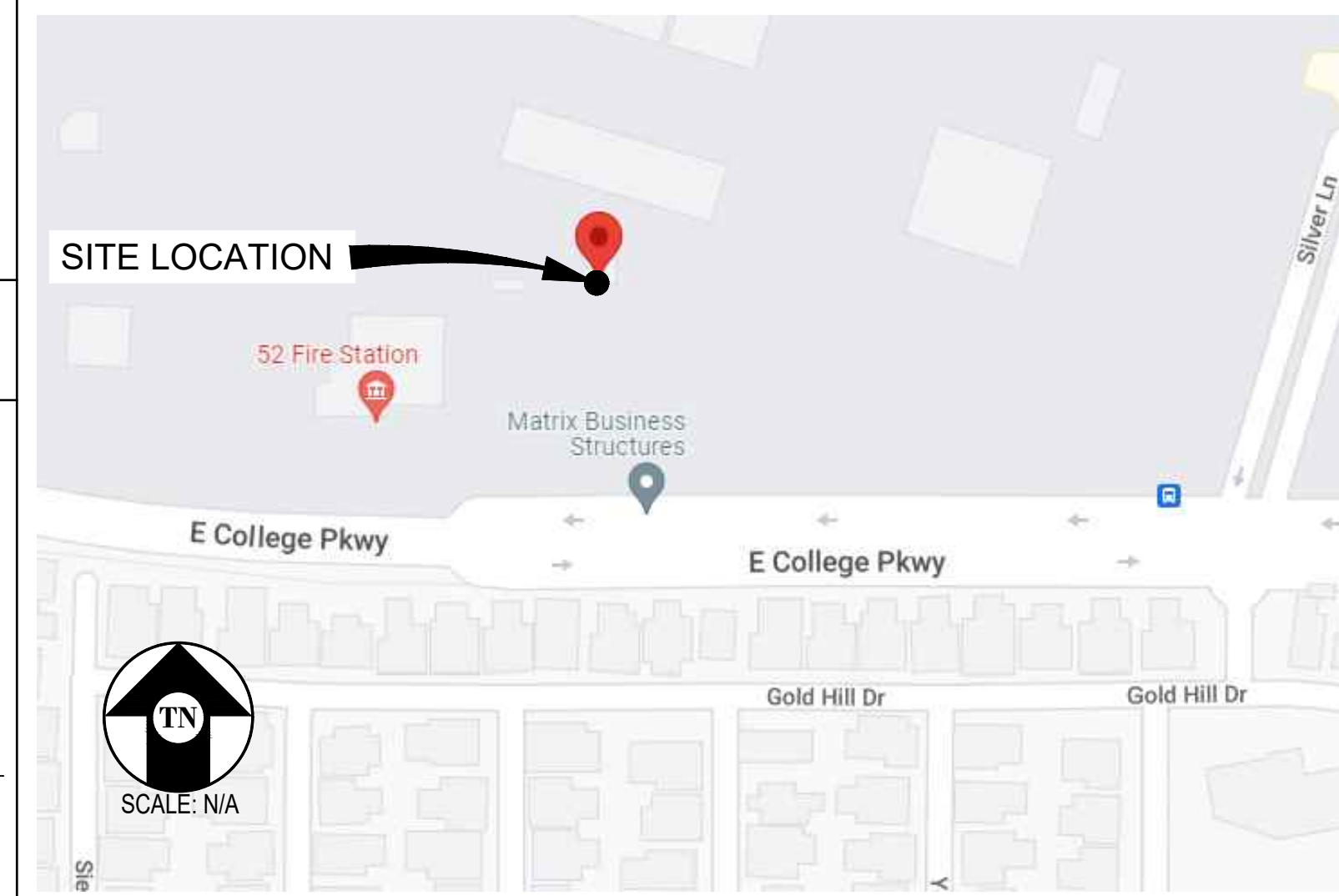

DRIVING DIRECTIONS

FROM: 2770 SHADELANDS DR, BLDG 11, WALNUT CREEK, CA 94598
TO: 2600 E COLLEGE PARKWAY, CARSON CITY, NV 89706

1. HEAD NORTHEAST ON MITCHELL DR 0.2 MI
2. USE THE LEFT 2 LANES TO TURN LEFT ONTO OAK GROVE RD 0.5 MI
3. USE THE LEFT 2 LANES TO TURN LEFT ONTO TREAT BLVD 2.2 MI
4. TURN RIGHT ONTO BUSKIRK AVE 0.2 MI
5. TAKE THE RAMP ON THE LEFT ONTO I-680 N 0.1 MI
6. MERGE ONTO I-680 N 1.8 MI
7. KEEP LEFT AT THE FORK TO STAY ON I-680 N 5.9 MI
8. KEEP LEFT AT THE FORK TO CONTINUE ON I-680 14.4 MI
9. TAKE EXIT 71A TOWARD I-80 E/SACRAMENTO 0.4 MI
10. MERGE ONTO I-80 E 41.0 MI
11. KEEP LEFT TO CONTINUE ON I-80BL E/US-50 E, FOLLOW SIGNS FOR SACRAMENTO/SOUTH LAKE TAHOE/CAPITAL CITY FREEWAY 5.0 MI
12. CONTINUE ONTO US-50 E/EL DORADO FWY 41.2 MI
13. CONTINUE STRAIGHT TO STAY ON US-50 E/EL DORADO FWY 52.4 MI
14. AT THE TRAFFIC CIRCLE, CONTINUE STRAIGHT ONTO US-50 E 0.1 MI
15. CONTINUE ONTO US-50 E 0.6 MI
16. CONTINUE STRAIGHT TO STAY ON US-50 E 0.2 MI
17. TURN RIGHT ONTO PIONEER TRAIL 8.0 MI
18. TURN RIGHT ONTO US-50 E/LAKE TAHOE BLVD 22.6 MI
19. CONTINUE ONTO I-580 N/US-50 4.6 MI
20. TAKE EXIT 5 TO MERGE ONTO US-50 E TOWARD DAYTON/FALLON 0.4 MI
21. MERGE ONTO US-50 E 0.4 MI
22. TURN LEFT ONTO AIRPORT RD 1.0 MI
23. TURN LEFT ONTO E COLLEGE PKWY 0.3 MI

END AT: 2600 E COLLEGE PARKWAY, CARSON CITY, NV 89706

ESTIMATED TIME: 4 HOUR 7 MINUTES ESTIMATED DISTANCE: 203 MILES

CODE COMPLIANCE

ALL WORK & MATERIALS SHALL BE PERFORMED & INSTALLED IN ACCORDANCE WITH THE CURRENT EDITIONS OF THE FOLLOWING CODES AS ADOPTED BY THE LOCAL GOVERNING AUTHORITIES. NOTHING IN THESE PLANS IS TO BE CONSTRUED TO PERMIT WORK NOT CONFORMING TO THESE CODES:

1. 2024 INTERNATIONAL BUILDING CODE AND NECESSARY ADMINISTRATIVE PROVISIONS
2. 2024 INTERNATIONAL RESIDENTIAL CODE AND NECESSARY ADMINISTRATIVE PROVISIONS
3. 2024 INTERNATIONAL EXISTING BUILDING CODE AND NECESSARY ADMINISTRATIVE PROVISIONS
4. 2024 INTERNATIONAL ENERGY CONSERVATION CODE
5. 2024 INTERNATIONAL FUEL GAS CODE
6. 2024 INTERNATIONAL MECHANICAL CODE AND NECESSARY ADMINISTRATIVE PROVISIONS
7. 2024 UNIFORM PLUMBING CODE AND NECESSARY ADMINISTRATIVE PROVISIONS
8. 2024 UNIFORM MECHANICAL CODE AND NECESSARY ADMINISTRATIVE PROVISIONS
9. 2023 NATIONAL ELECTRICAL CODE
10. 2024 NORTHERN NEVADA AMENDMENTS
11. CITY/COUNTY ORDINANCES
12. ANSI/TIA-222-1 - 2023

ALONG WITH ANY OTHER APPLICABLE LOCAL & STATE LAWS AND REGULATIONS.

SHEET INDEX

SHEET	DESCRIPTION	REV
T-1.1	TITLE SHEET	-
T-1.2	SPECIFICATION SHEETS & NOTES	-
A-1.1	SITE PLAN	-
A-2.1	SHELTER ROOF PLAN	-
A-3.1	ELEVATIONS	-
S-1.1	DETAILS	-

DESIGN CRITERIA

RISK CATEGORY: II	ROOF LIVE LOAD: N/A	FLOOR LIVE LOAD: N/A	ALLOW SOIL BEARING: N/A
WIND EXPOSURE: C	DESIGN WIND SPEED: 120 MPH	GROUND ELEVATION: 4689	TOPOGRAPHIC CATEGORY: I
SEISMIC SITE CLASS: D	SEISMIC DESIGN CATEGORY: D	SEISMIC COMPONENT I _s : 1.0	α _p : 1.0 R _p : 2.5
S _{ps} : 1.72	S _{ps} : 1.22	S _s : 2.5	S _f : 0.8

TESTS AND SPECIAL INSPECTIONS

STREAMLINE ENGINEERING & DESIGN, INC. DOES NOT REQUIRE ANY STRUCTURAL OBSERVATION OR SPECIAL INSPECTION OF ANY STRUCTURAL COMPONENT ABOVE & BEYOND WHAT IS LISTED BELOW UNLESS OTHERWISE REQUIRED BY JURISDICTION.

PROVIDE COMPLETE TESTING AND INSPECTIONS IN ACCORDANCE WITH THE IBC, CHAPTER 17 AS NOTED BELOW:

1. POST INSTALLED ANCHORS IN ACCORDANCE WITH CURRENT ICC REPORTS FOR THE SPECIFIED ANCHORAGES.

PROJECT GENERAL NOTES

- THIS FACILITY IS AN UNOCCUPIED WIRELESS TELECOMMUNICATION FACILITY.
- PLANS ARE NOT TO BE SCALED AND ARE INTENDED TO BE A DIAGRAMMATIC OUTLINE ONLY, UNLESS NOTED OTHERWISE.
- THE SCOPE OF WORK SHALL INCLUDE FURNISHING MATERIALS, EQUIPMENT, APPURTENANCES AND LABOR NECESSARY TO COMPLETE ALL INSTALLATIONS AS INDICATED ON THE DRAWINGS.
- PRIOR TO THE SUBMISSION OF BIDS, THE CONTRACTORS SHALL VISIT THE JOB SITE AND BE RESPONSIBLE FOR ALL CONTRACT DOCUMENTS, FIELD CONDITIONS AND DIMENSIONS, AND CONFIRM THAT THE WORK MAY BE ACCOMPLISHED AS SHOWN PRIOR TO PROCEEDING WITH CONSTRUCTION. ANY DISCREPANCIES ARE TO BE BROUGHT TO THE ATTENTION OF THE CONSTRUCTION MANAGER AND ENGINEER PRIOR TO PROCEEDING WITH THE WORK.
- IT IS THE RESPONSIBILITY OF THE CONTRACTOR TO PAY FOR PERMIT FEES, AND TO OBTAIN SAID PERMITS AND TO COORDINATE INSPECTIONS.
- THE CONTRACTOR SHALL RECEIVE, IN WRITING, AUTHORIZATION TO PROCEED BEFORE STARTING WORK ON ANY ITEM NOT CLEARLY DEFINED OR IDENTIFIED BY THE CONTRACT DOCUMENTS.
- CALL BEFORE YOU DIG. CONTRACTOR IS REQUIRED TO CALL 811 (NATIONWIDE "CALL BEFORE YOU DIG" HOTLINE) AT LEAST 72 HOURS BEFORE DIGGING.
- ALL WORK PERFORMED AND MATERIALS INSTALLED SHALL BE IN STRICT ACCORDANCE WITH ALL APPLICABLE CODES, REGULATIONS, AND ORDINANCES. CONTRACTOR SHALL GIVE ALL NOTICES AND COMPLY WITH ALL LAWS, ORDINANCES, RULES, REGULATIONS AND LAWFUL ORDERS OF ANY PUBLIC AUTHORITY REGARDING THE PERFORMANCE OF THE WORK.
- THE GENERAL CONTRACTOR SHALL SUPERVISE AND DIRECT THE WORK USING THE BEST SKILLS AND ATTENTION. THE CONTRACTOR SHALL BE SOLELY RESPONSIBLE FOR ALL CONSTRUCTION MEANS, METHODS, TECHNIQUES, SEQUENCES AND PROCEDURES. CONTRACTOR SHALL ALSO COORDINATE ALL PORTIONS OF THE WORK UNDER THE CONTRACT, INCLUDING CONTACT AND COORDINATION WITH THE CONSTRUCTION MANAGER AND WITH THE LANDLORD'S AUTHORIZED REPRESENTATIVE.
- THE CONTRACTOR SHALL MAKE NECESSARY PROVISIONS TO PROTECT EXISTING IMPROVEMENTS, PAVING, CURBS, GALVANIZED SURFACES, ETC., AND UPON COMPLETION OF WORK, REPAIR ANY DAMAGE THAT OCCURRED DURING CONSTRUCTION TO THE SATISFACTION OF THE PROJECT MANAGER.
- KEEP GENERAL AREA CLEAN, HAZARD FREE, AND DISPOSE OF ALL DIRT, DEBRIS AND RUBBISH. REMOVE EQUIPMENT NOT SPECIFIED AS REMAINING ON THE PROPERTY. LEAVE PREMISES IN CLEAN CONDITION AND FREE FROM PAINT SPOTS, DUST, OR SMUDGES OF ANY NATURE.
- ALL EXISTING INACTIVE SEWER, WATER, GAS, ELECTRIC, AND OTHER UTILITIES, WHICH INTERFERE WITH THE EXECUTION OF THE WORK, SHALL BE REMOVED AND/OR CAPPED, PLUGGED, OR OTHERWISE DISCONNECTED AT POINTS WHICH WILL NOT INTERFERE WITH THE EXECUTION OF THE WORK, AS DIRECTED BY THE RESPONSIBLE ENGINEER, AND SUBJECT TO THE APPROVAL OF THE OWNER AND/OR LOCAL UTILITIES.
- ALL EXISTING ACTIVE SEWER, WATER, GAS, ELECTRIC AND ALL OTHER UTILITIES WHERE ENCOUNTERED IN THE WORK SHALL BE PROTECTED AT ALL TIMES.
- DETAILS ARE INTENDED TO SHOW END RESULT OF DESIGN. MINOR MODIFICATIONS MAY BE REQUIRED TO SUIT JOB DIMENSIONS OR CONDITIONS, AND SUCH MODIFICATIONS SHALL BE INCLUDED AS PART OF THE WORK.
- THE CONTRACTOR SHALL PROVIDE A TOILET FACILITY DURING ALL PHASES OF CONSTRUCTION.
- SUFFICIENT MONUMENTATION WAS NOT RECOVERED TO ESTABLISH THE POSITION OF THE BOUNDARY LINES SHOWN HEREON. THE BOUNDARY REPRESENTED ON THIS MAP IS BASED ON COMPILED RECORD DATA AND BEST FIT ONTO EXISTING IMPROVEMENTS. IT IS POSSIBLE FOR THE LOCATION OF THE SUBJECT PROPERTY TO SHIFT FROM THE PLACEMENT SHOWN HEREON WITH ADDITIONAL FIELD WORK AND RESEARCH. THEREFORE ANY SPATIAL REFERENCE MADE OR SHOWN BETWEEN THE RELATIONSHIP OF THE BOUNDARY LINES SHOWN HEREON AND EXISTING GROUND FEATURES, EASEMENTS OR LEASE AREA IS INTENDED TO BE APPROXIMATE AND IS SUBJECT TO VERIFICATION BY RESOLVING THE POSITION OF THE BOUNDARY LINES.
- THE CONTRACTOR TO VERIFY THE LATEST/CURRENT RF DESIGN.
- WHERE APPLICABLE, CONTRACTOR SHALL PROVIDE SEPARATE PLANS, SPECIFICATIONS, FEES AND PERMITS FOR ANY REVISION TO ANY FIRE SPRINKLER AND/OR ALARM SYSTEM ON THE PREMISES AS MAY BE NEEDED TO COMPLETE THE WORK DEPICTED HEREIN, USING A LICENSED SUBCONTRACTOR FOR ALL SUCH WORK.

EXPANSION & EPOXY ANCHORS

- EXPANSION AND EPOXY ANCHORS SHALL BE IN CONFORMANCE WITH ALL REQUIREMENTS OF THE 2024 IBC.
- ALL ANCHORS PROVIDED SHALL BE INCLUDED IN EVALUATION REPORTS OF THE INTERNATIONAL CODE COUNCIL (ICC), AND SHALL BE EVALUATED FOR 2024 IBC MINIMUM REQUIREMENTS IN THE ICC REPORT
- CONCRETE EXPANSION ANCHORS SHALL BE KWIK BOLT T22 BY HILTI, INC., TULSA, OKLAHOMA AS PER ICC REPORT NO. ESR-4266 OR APPROVED EQUIVALENT.
- CMU EXPANSION ANCHORS SHALL BE KWIK BOLT T22 BY HILTI, INC., TULSA, OKLAHOMA AS PER ICC REPORT NO. ESR-4561 OR APPROVED EQUIVALENT. ANCHORS SHALL BE INSTALLED A MINIMUM OF 1 3/8" FROM ANY VERTICAL MORTAR JOINT TYPICAL. ANCHORS TO BE SPACED 8 INCHES ON CENTER MINIMUM AND LIMITED TO ONE ANCHOR PER CELL. NOTE: ESR-4561 - NOT TESTED TO 2024 IBC YET
- CONCRETE ADHESIVE EPOXY ANCHORS SHALL BE HIT RE-500 V3 BY HILTI, INC., TULSA, OKLAHOMA AS PER ICC REPORT NO. ESR-3814 OR APPROVED EQUIVALENT.
- GROUT FILLED CMU ADHESIVE EPOXY ANCHORS SHALL BE HIT-HY 200 V3 BY HILTI, INC., TULSA, OKLAHOMA AS PER ICC REPORT NO. ESR-4878 OR APPROVED EQUIVALENT.
- INSTALL EXPANSION AND EPOXY ANCHORS WITH SPECIAL INSPECTION IN ACCORDANCE WITH THE 2024 IBC, TABLE 1705.3, AND ALL REQUIREMENTS OF THE MANUFACTURER, THE MANUFACTURER'S ICC APPROVAL AND THESE DRAWINGS.
- EXPANSION ANCHORS SHALL BE 304/316 STAINLESS STEEL U.O.N. EPOXY ANCHOR THREADED ROD SHALL BE ASTM F593 CW1 (316) (1/4" TO 3/8") OR F593 CW2 (316) (3/4" TO 1 1/2") STAINLESS STEEL U.O.N.
- LOCATE AND AVOID REINFORCEMENT AND OTHER EMBEDDED ITEMS WHEN INSTALLING ANCHORS, TYPICAL. SEE CONCRETE CORE DRILLING NOTES FOR ADDITIONAL INFORMATION.
- THE SPECIAL INSPECTOR MUST MAKE PERIODIC INSPECTIONS DURING ANCHOR INSTALLATION TO VERIFY ANCHOR TYPE AND DIMENSIONS, CONCRETE MEMBER THICKNESS, ANCHOR SPACING, EDGE DISTANCES, TIGHTENING TORQUE, HOLE DIAMETER, DEPTH AND CLEANLINESS, ANCHOR EMBEDMENT AND ADHERENCE TO MANUFACTURER'S INSTALLATION INSTRUCTIONS. SEE NOTE 11 BELOW FOR FREQUENCY OF INSPECTIONS.
- 50% OF ALL ANCHORS, INCLUDING ALTERNATE BOLTS IN A GROUP OF ANCHORS, SHALL BE INSPECTED PER NOTE 10 ABOVE AND TORQUE TESTED PER THE ICC REPORT TEST VALUES NOTED BELOW:

KB T22

CONCRETE TORQUE TEST VALUES:

3/8" = 30 FT LB 1/2" = 40 FT LB 5/8" = 60 FT LB 3/4" = 125 FT LB

CMU TORQUE TEST VALUES:

3/8" = 15 FT LB 1/2" = 15 FT LB 5/8" = 35 FT LB 3/4" = 50 FT LB

EPOXY ANCHOR

CONCRETE TORQUE TEST VALUES:

1/2" = 30 FT LB
(CONCRETE TENSION TEST VALUES TO BE DETERMINED AS NEEDED. A RFI WILL BE ISSUED IF NEEDED DURING CONSTRUCTION TO ESTABLISH THE REQUIRED TENSION TEST VALUES)

CONSTRUCTION NOTES

- EXISTING BUILDING CONSTRUCTION CONDITIONS INDICATED ON THE DRAWINGS SHALL BE FIELD VERIFIED BY THE CONTRACTOR PRIOR TO PROCEEDING WITH CONSTRUCTION OR ORDERING OF MATERIALS. IF EXISTING CONDITIONS DO NOT ALLOW FOR DETAILS OF CONSTRUCTION AS SHOWN ON THESE DRAWINGS, NOTIFY ENGINEER OF RECORD FOR RESOLUTION PRIOR TO PROCEEDING. CONTRACTOR SHALL EXPOSE AND REVIEW EXISTING CONDITIONS IN A TIMELY MANNER SUCH THAT ALTERNATE DESIGNS OR DETAILS, IF REQUIRED, MAY BE GENERATED WITHOUT DELAY TO THE PROJECT.
- DURING CONSTRUCTION, THE CONTRACTOR SHALL NOT ALTER, DAMAGE OR REMOVE ANY PART OF THE EXISTING STRUCTURE UNLESS SPECIFICALLY DETAILED ON THESE DRAWINGS. THE INTENT OF THESE DRAWINGS IS THAT THE WORK OF THE ADDITION, ALTERATION, REHABILITATION, OR RECONSTRUCTION IS TO BE IN ACCORDANCE WITH THE 2024 IBC. SHOULD ANY EXISTING CONDITIONS SUCH AS DETERIORATION OR NONCOMPLYING CONSTRUCTION BE DISCOVERED WHICH IS NOT COVERED BY THE CONTRACT DOCUMENTS WHEREIN THE FINISHED WORK WILL NOT COMPLY WITH THE 2024 IBC, A CHANGE ORDER, OR A SEPARATE SET OF PLANS AND SPECIFICATIONS, DETAILING AND SPECIFYING THE REQUIRED WORK SHALL BE PREPARED AND SUBMITTED TO AND APPROVED BY THE BUILDING DEPARTMENT PRIOR TO PROCEEDING WITH THE WORK.
- ALL WORK AND MATERIALS SHOWN ARE NEW UNLESS INDICATED AS EXISTING (E). IT MAY BE NECESSARY TO REMOVE ARCHITECTURAL FINISHES, PLUMBING PIPES AND FIXTURES, ELECTRICAL CONDUIT, FIXTURES, PANELS, BOXES, TELEPHONE OR FIRE ALARM WIRING AND FIXTURES OR OTHER NON-STRUCTURAL ITEMS TO INSTALL STRUCTURAL WORK AND MATERIALS SHOWN ON THESE DRAWINGS. SUCH ITEMS SHALL BE REMOVED, REPAIRED AND/OR REPLACED TO MATCH PRE-CONSTRUCTION CONDITIONS AT THE CONTRACTORS EXPENSE.
- ALL WEATHER PROOFING, INCLUDING BUT NOT LIMITED TO TORCH DOWN, CAULKING, Z-FLASHING OR ANY OTHER MATERIAL THAT MAY BE ALTERED DURING INSTALLATION SHALL BE REPAIRED REPLACED AND/OR MODIFIED TO ENSURE THE BUILDING AT THE INSTALLATION SITE IS WEATHER PROOF.
- ANY PROPOSED SUBSTITUTIONS FOR STRUCTURAL MEMBERS, HARDWARE, ANCHOR TYPES, OR DETAILING INDICATED IN THESE DRAWINGS SHALL BE SUBMITTED TO AND REVIEWED BY THE ENGINEER OF RECORD PRIOR TO ORDERING MATERIALS. SUCH REVIEW SHALL BE BILLED ON A TIME AND MATERIALS BASIS TO THE CONTRACTOR WITH NO GUARANTEE THAT THE SUBSTITUTION WILL BE ALLOWED.
- CONTRACTOR SHALL ENSURE ALL ROOF AREAS HAVE POSITIVE SLOPE TO ALL EXISTING ROOF DRAINS. PROVIDE ADDITIONAL CRICKETS OR BUILD UP ROOFING AS REQUIRED TO PROVIDE POSITIVE DRAINAGE AROUND ALL NEW CONSTRUCTION INCLUDING ANY CURBS, SLEEPERS, SUPPORT BASES, ETC.

CONCRETE CORE/DRILLING NOTES

- WHEN INSTALLING DRILLED-IN ANCHORS AND/OR POWDER DRIVEN PINS IN EXISTING NON-PRESTRESSED OR POST-TENSIONED REINFORCED CONCRETE (MILD REINFORCED), USE CARE & CAUTION TO AVOID CUTTING OR DAMAGING THE (E) REINFORCING BARS. WHEN INSTALLING ANCHORS INTO (E) PRE-STRESSED OR POST-TENSIONED CONCRETE LOCATE THE PRE-STRESSED OR POST-TENSIONED TENDONS BY USING A NON-DESTRUCTIVE METHOD, SUCH AS X-RAY, AT POINT OF PENETRATION, PRIOR TO INSTALLATION. EXERCISE EXTREME CARE & CAUTION TO AVOID CUTTING OR DAMAGING THE TENDONS DURING INSTALLATION. MAINTAIN A MINIMUM CLEARANCE OF TWO INCHES BETWEEN REINFORCEMENT AND THE DRILLED-IN ANCHOR AND/OR PIN.
- WHEN CORING EXISTING REINFORCED CONCRETE OF ANY CONSTRUCTION TYPE (PRE-STRESSED, POST-TENSIONED OR MILD REINFORCED), LOCATE THE EXISTING REINFORCING BY USING A NON-DESTRUCTIVE METHOD, SUCH AS X-RAY, PRIOR TO CORING. EXERCISE EXTREME CARE & CAUTION TO AVOID CUTTING OR DAMAGING ANY REINFORCING DURING CORING. MAINTAIN A MINIMUM CLEARANCE OF TWO INCHES BETWEEN REINFORCEMENT AND THE CORE. THE MAXIMUM SIZE OF ANY CORE IS TO BE 6" DIAMETER AND THE MINIMUM SPACING BETWEEN CORES IS TO BE TWICE THE CORE DIAMETER (I.E. 12" SPACING FOR A 6" DIAMETER CORE).
- INSPECTOR IS TO BE PRESENT DURING ALL CORE DRILLING OPERATIONS TO VERIFY THAT NO REINFORCING CABLES, TENDONS, OR REBAR HAVE BEEN CUT. (SEE NOTE 5 BELOW)
- THE INSPECTOR SHALL SUBMIT A WRITTEN REPORT TO THE OWNER.
- THE INSPECTIONS INDICATED IN NOTES 3 AND 4 ABOVE ARE NOT REQUIRED FOR A CONCRETE FILL OVER METAL DECK APPLICATION WHERE INDICATED ON THE CONSTRUCTION DRAWINGS.

STRUCTURAL STEEL NOTES

- ALL STEEL CONSTRUCTION INCLUDING FABRICATION, ERECTION AND MATERIALS SHALL COMPLY WITH ALL REQUIREMENTS OF THE 2022 AISC SPECIFICATION FOR THE DESIGN, FABRICATION, AND ERECTION OF STRUCTURAL STEEL FOR BUILDINGS AND THE 2024 IBC.
- ALL STRUCTURAL STEEL SHALL BE ASTM A36 UNLESS OTHERWISE NOTED. ALL WF (WIDE FLANGE) & WT (TEE) SHAPES TO BE ASTM A992 (F_y=50,000 PSI) UNLESS NOTED OTHERWISE. ALL STRUCTURAL TUBING (TS OR HSS) SHALL BE ASTM A500 GRADE C (F_y=50,000 PSI FOR RECT HSS & F_y=46,000 PSI FOR ROUND HSS PER AISC MANUAL TABLE 2-4) ALL STEEL PIPE SHALL BE ASTM A53 (TYPE E OR S, GRADE B (F_y=35,000 PSI)) SCHEDULE 40 WITH OUTSIDE DIAMETERS GIVEN UNLESS OTHERWISE NOTED.
- ALL WELDING SHALL BE PERFORMED USING E70XX ELECTRODES UNLESS OTHERWISE NOTED AND SHALL CONFORM TO AISC & AWS D1.4. WHERE FILLET WELD SIZES ARE NOT SHOWN PROVIDE THE MINIMUM SIZE PER TABLE J2.4 IN THE AISC SPECIFICATION. PAINTED SURFACES SHALL BE TOUCHED UP.
- ALL WELDING SHALL BE PERFORMED BY QUALIFIED, CERTIFIED WELDERS.
- HIGH STRENGTH BOLTS SHALL BE GALVANIZED ASTM F3125/F3125M GRADE A325 MINIMUM. BOLTED CONNECTIONS SHALL BE BEARING TYPE. SEE PLANS FOR LOCATION, NUMBER, & SIZE OF BOLTS.
- HIGH STRENGTH BOLT NUTS SHALL BE ASTM A563/A563M AND WASHERS SHALL BE ASTM F436/ F436M.
- THREADED RODS SHALL BE ASTM F1554, GR 36 U.O.N. BOLTED CONNECTIONS SHALL BE BEARING TYPE.
- ALL HOLES FOR BOLTED CONNECTIONS SHALL BE 1/16" LARGER THAN THE NOMINAL BOLT DIAMETER. USE STANDARD AISC GAGE AND PITCH FOR BOLTS EXCEPT AS NOTED OTHERWISE. HOLES FOR ANCHOR BOLTS IN BASE PLATES MAY BE AISC "OVERSIZE" HOLES WHERE ACCOMPANIED BY OVERSIZED HARDENED HOT DIPPED GALVANIZED WASHERS.
- ALL SHOP FABRICATED STEEL STRUCTURAL MEMBERS FOR EXTERIOR USE SHALL BE HOT DIP GALVANIZED PER ASTM A123 AFTER FABRICATION & PAINTED PER CUSTOMER SPECIFICATIONS AS REQUIRED. STEEL FOR INTERIOR USE SHALL BE SHOP COAT OR GALVANIZED & PAINTED.
- ALL FIELD FABRICATED GALVANIZED STEEL THAT IS CUT, GROUND, DRILLED, WELDED OR DAMAGED SHALL BE TREATED WITH "ZINC RICH" COLD GALVANIZING SPRAY OR COATING. NO RAW STEEL SHALL BE EXPOSED.
- AT ALL WEB STIFFENER PLATES LEAVE 3/4"Ø (OR K, WHICHEVER IS LARGER) HOLE @ WEB/FLANGE INTERSECTION UNLESS NOTED OTHERWISE.
- U-BOLTS AT ANTENNA & RRU MOUNT TO BE GALVANIZED SAE J429, GRADE 2 WITH J995 NUTS U.O.N.
- ALL STRUT MEMBERS USED IN EXTERIOR APPLICATIONS SHALL BE HOT DIPPED GALVANIZED PER ASTM A123 OR ASTM A153.
- ALL STAINLESS STEEL BOLTED CONNECTIONS SHALL BE ASTM F593-17 ALLOY GROUP 1 OR 2 AND STAINLESS STEEL NUTS SHALL BE ASTM F594-09 (2015).



Microwave Antenna Specifications

SLA032853S49A20
0.3m Ultra High Performance Antenna
Flange Type Rectangular



Electrical Specifications	
Frequency (GHz)	27.5~29.5
Polarization	Single(V or H)
Gain , Low(dBi)	37.7
Gain , Mid(dBi)	38
Gain , Top(dBi)	38.3
Beam Width	2.0°
Cross-pol. Discrimination_XPD (dB)	30
F/B Ratio (dB)	64
VSWR / RL (dB)	1.3/17.7
Regulatory Compliance	ETSI EN 302217 Range 4 Class 3

Mechanical Specifications	
Diameter (m)	0.3
Antenna Color	Cool Gray 1C
Radome Options	Foam
Interface Type	UBR320 OR Customized
Side Struts, Included	0
Azimuth Adjustment	Coarse : 360 ° Fine : ±15 °
Elevation Adjustment	Fine : ±15 °
Diameter of Mounting Pole (mm)	Ø51*Ø114
Wind Velocity Survival Rating (km/h)	252
Wind Velocity Operational (km/h)	200
Ice-load (mm)	25.4
Operational Temperature (°C)	-45~+60
Packaging	Carton
LxWxH (mm)	480*480*267

Wind Load Specifications		Dimensions (mm)			
Axial Force (N) @ survival wind speed	Side Force (N) @ survival wind speed	ΦA	B	C	D
444	219	386	318	137	180

Note:
1. The values of B and C are measured at the pole diameter of 114mm
2. The thickness of the radome is not included in the dimensions of A and C

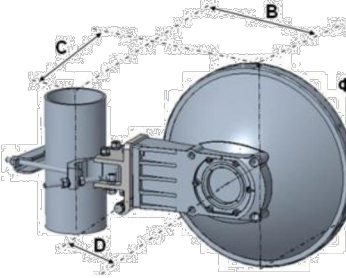

Guangdong Shenglu Telecommunication Tech. Co., Ltd. Revision 2.1 2020-Nov
Add: No. 4 Jinye Second Road, Xilun Industry Area, Sanshan District, Foshan City, Guangdong Province, China
Phone: 86-757-87119589
Fax: 86-757-87144987
Email: sales@shenglu.com
Website: http://www.shenglu.com

PART NO.	MAST DIAMETER	WEIGHT
B3-131X25	1.31"OD [33.4mm]	33 lbs. [15.0kg]
B3-166X25	1.66"OD [42.2mm]	35 lbs. [15.9kg]
B3-190X25	1.90"OD [48.3mm]	36 lbs. [15.3kg]
B3-200X25	2"OD [50.8mm]	36 lbs. [16.3kg]
B3-237X25	2.37"OD [60.3mm]	38 lbs. [17.2kg]
B3-288X25	2.88"OD [73mm]	38 lbs. [17.2kg]
B3-300X25	3"OD [76.2mm]	38 lbs. [17.2kg]

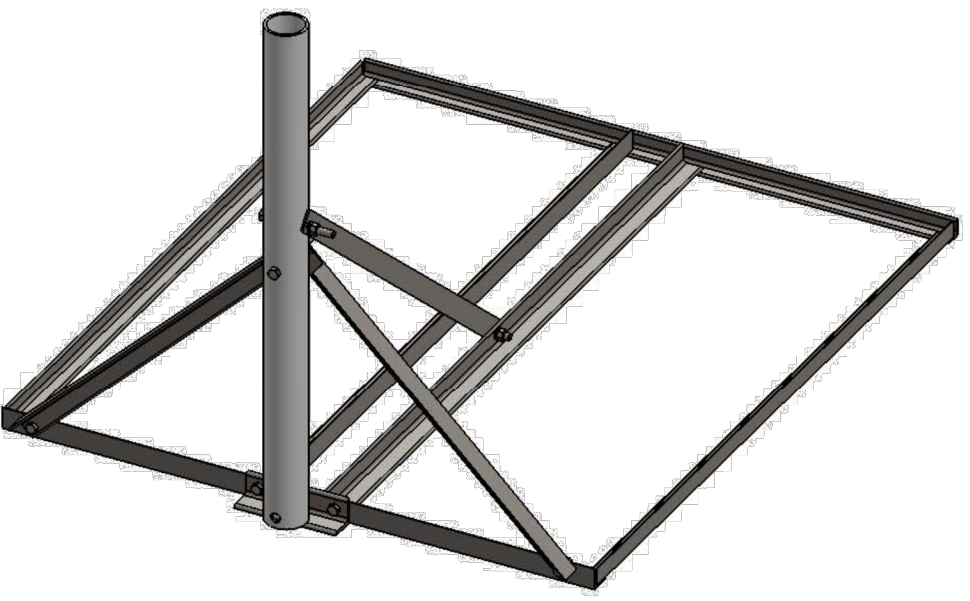

PROPRIETARY AND CONFIDENTIAL		BAIRD MOUNTING SYSTEMS		DRAWN BY		DATE	
THE INFORMATION CONTAINED IN THIS DRAWING IS THE SOLE PROPERTY OF BAIRD SUPPORTING SYSTEMS. ANY REPRODUCTION IN PART OR AS A WHOLE WITHOUT THE WRITTEN PERMISSION OF BAIRD SUPPORTING SYSTEMS IS PROHIBITED.		WATERLOO, IA 50103 PHONE: 319-233-3561 SALES@BAIRD MOUNTS.COM		JK		05/03/13	
		UNLESS OTHERWISE SPECIFIED: DIMENSIONS ARE IN INCHES TOLERANCES: FRACTIONAL ± ANGULAR: MACH ± END ± TWO PLACE DECIMAL ± THREE PLACE DECIMAL ±		HDC		HDC	
		DO NOT SCALE DRAWING		CUSTOMER		1 OF 2 1:10	
		TITLE: B3-34X40 MOUNT WITH 2.5" MAST		PART: NO. SEE TABLE		DWG. NO. B3-(000)X25	
		WWW.BAIRD MOUNTS.COM					

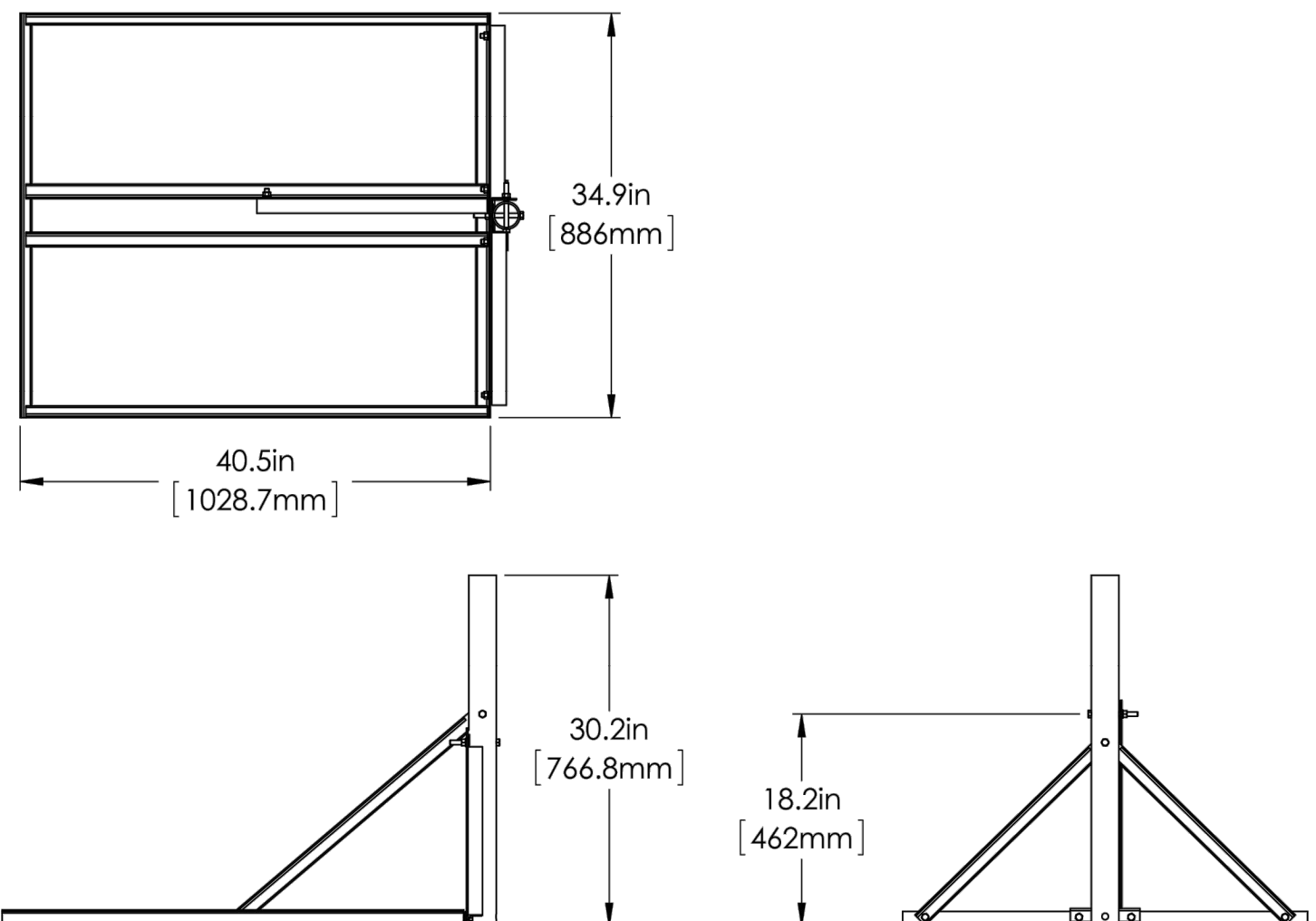

PROPRIETARY AND CONFIDENTIAL		BAIRD MOUNTING SYSTEMS		DRAWN BY		DATE	
THE INFORMATION CONTAINED IN THIS DRAWING IS THE SOLE PROPERTY OF BAIRD SUPPORTING SYSTEMS. ANY REPRODUCTION IN PART OR AS A WHOLE WITHOUT THE WRITTEN PERMISSION OF BAIRD SUPPORTING SYSTEMS IS PROHIBITED.		WATERLOO, IA 50103 PHONE: 319-233-3561 SALES@BAIRD MOUNTS.COM		JK		05/03/13	
		UNLESS OTHERWISE SPECIFIED: DIMENSIONS ARE IN INCHES TOLERANCES: FRACTIONAL ± ANGULAR: MACH ± BEND ± TWO PLACE DECIMAL ± THREE PLACE DECIMAL ±		HDC		HDC	
		DO NOT SCALE DRAWING		CUSTOMER		2 OF 2 1:15	
		TITLE: B3-34X40 MOUNT WITH 2.5" MAST		PART: NO. SEE TABLE-SHEET 1		DWG. NO. B3-(000)X25	
		WWW.BAIRD MOUNTS.COM					

Issued For:

CARSON CITY AIRPORT

2600 E COLLEGE PARKWAY
CARSON CITY, NV 89706

PREPARED FOR

verizon

2770 SHADELANDS DR, BLDG 11
WALNUT CREEK, CA 94598

Vendor:

EPIC
WIRELESS GROUP LLC
Connecting a Wireless World

MDG LOCATON ID: 5000246353

PROJECT NO: 17556403

DRAWN BY: J. ZHAR

CHECKED BY: K. SORENSEN

APPROVED BY: J. SPORE

ISSUE STATUS

REV	DATE	DESCRIPTION	CAD
1	02/04/26	CD 100%	A.M.
0	01/28/26	CD 90%	J.Z.

Licensee:



02/04/2026

IT IS A VIOLATION OF LAW FOR ANY PERSON, UNLESS THEY ARE ACTING UNDER THE DIRECTION OF A LICENSED PROFESSIONAL ENGINEER, TO ALTER THIS DOCUMENT.

ENGINEER:



3840 Taylor Road, Suite A, Leominster, MA 01450
Contact: Kevin Sorenson Phone: 916-660-1800
E-Mail: kevin@streamlineeng.com Fax: 916-660-1941

THESE PLANS AND SPECIFICATIONS ARE INSTRUMENTS OF SERVICE AND SHALL REMAIN THE PROPERTY OF STREAMLINE ENGINEERING AND DESIGN INC. ANY REPRODUCTION OR ALTERATION OF THESE PLANS OR SPECIFICATIONS WITHOUT THE WRITTEN PERMISSION OF STREAMLINE ENGINEERING AND DESIGN INC. IS PROHIBITED.
COPYRIGHT © 2006, STREAMLINE ENGINEERING AND DESIGN INC. ALL RIGHTS RESERVED.

SHEET TITLE:

SPECIFICATION SHEETS & NOTES

SHEET NUMBER:

T-1.2

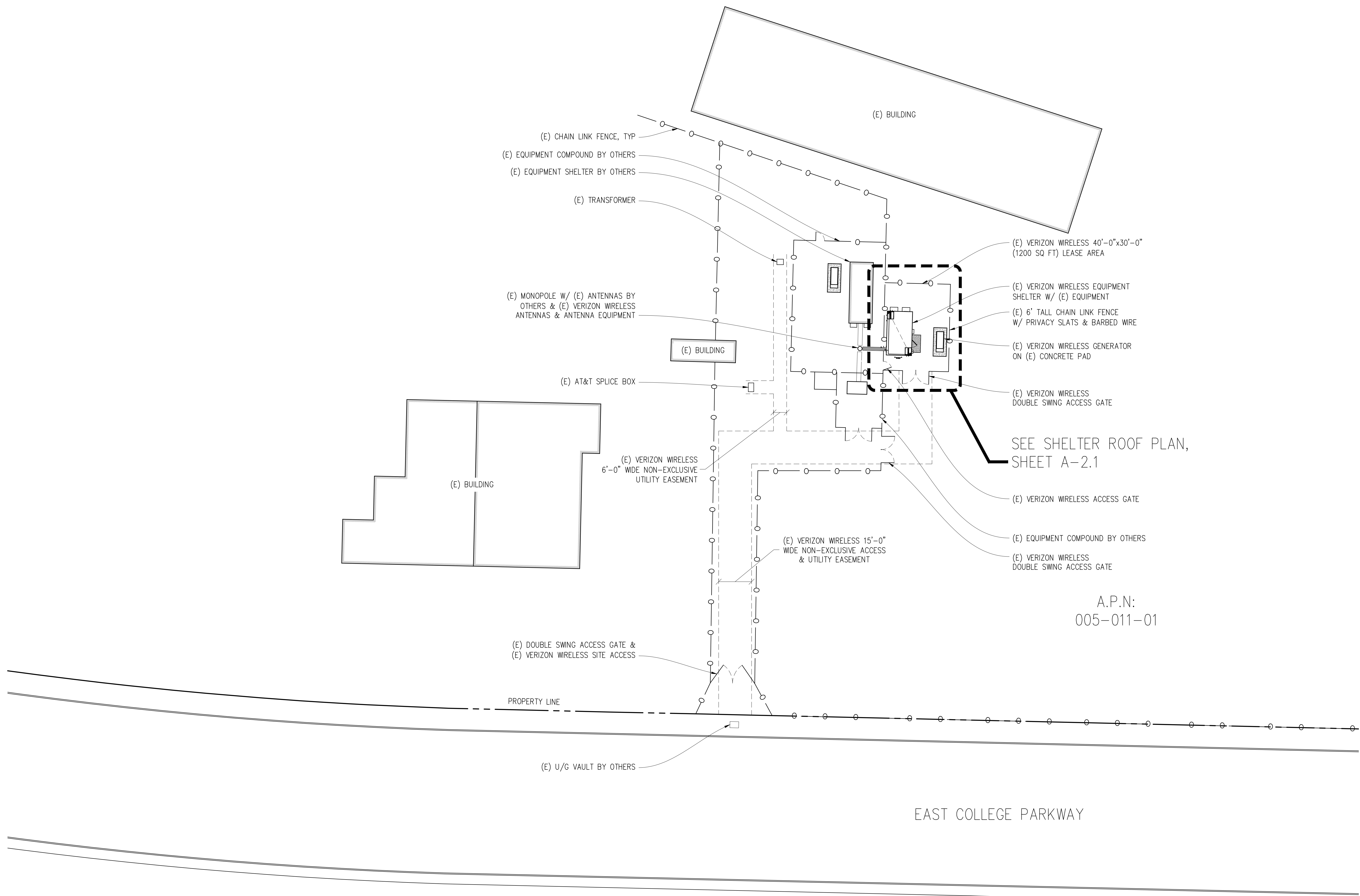

Issued For:
CARSON CITY AIRPORT
 2600 E COLLEGE PARKWAY
 CARSON CITY, NV 89706

PREPARED FOR

 2770 SHADELANDS DR, BLDG 11
 WALNUT CREEK, CA 94598

Vendor:

 Connecting a Wireless World

MDG LOCATION ID: 5000246353
 PROJECT NO: 17556403
 DRAWN BY: J. ZHAR
 CHECKED BY: K. SORENSEN
 APPROVED BY: J. SPORE

ISSUE STATUS			
REV	DATE	DESCRIPTION	CAD
1	02/04/26	CD 100%	A.M.
0	01/28/26	CD 90%	J.Z.

Licensee:

 02/04/2026
 IT IS A VIOLATION OF LAW FOR ANY PERSON, UNLESS THEY ARE ACTING UNDER THE DIRECTION OF A LICENSED PROFESSIONAL ENGINEER, TO ALTER THIS DOCUMENT.

ENGINEER:

 3843 Taylor Road, Suite A, Lovins, CA 94560
 Contact: Kevin Sorenson Phone: 916-660-1930
 E-Mail: kevin@streamlineeng.com Fax: 916-660-1941
THESE PLANS AND SPECIFICATIONS AS INSTRUMENTS OF SERVICE ARE AND SHALL REMAIN THE PROPERTY OF STREAMLINE ENGINEERING AND SHALL BE KEPT IN THE OFFICE OF THE ENGINEER. THESE PLANS ARE VALID ONLY FOR THE PROJECT AND SPECIFICATIONS SHOWN ON THESE PLANS. NO PART OF THESE PLANS OR SPECIFICATIONS SHALL BE REPRODUCED OR TRANSMITTED IN ANY FORM OR BY ANY MEANS, ELECTRONIC OR MECHANICAL, INCLUDING PHOTOCOPYING, RECORDING, OR BY ANY INFORMATION STORAGE AND RETRIEVAL SYSTEM, WITHOUT THE WRITTEN PERMISSION OF STREAMLINE ENGINEERING AND DESIGN INC. ALL RIGHTS RESERVED. ENGINEER: Copyright © 2026, STREAMLINE ENGINEERING AND DESIGN INC.

SHEET TITLE:
SITE PLAN

SHEET NUMBER:
A-1.1

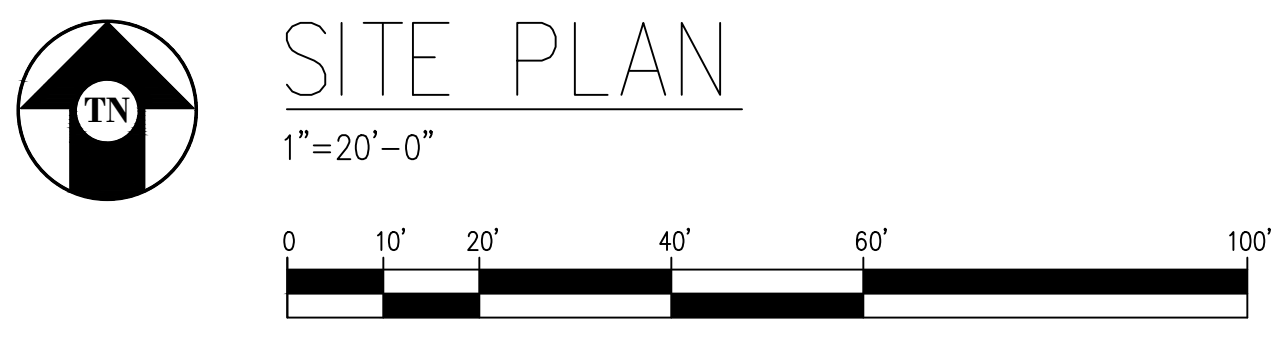

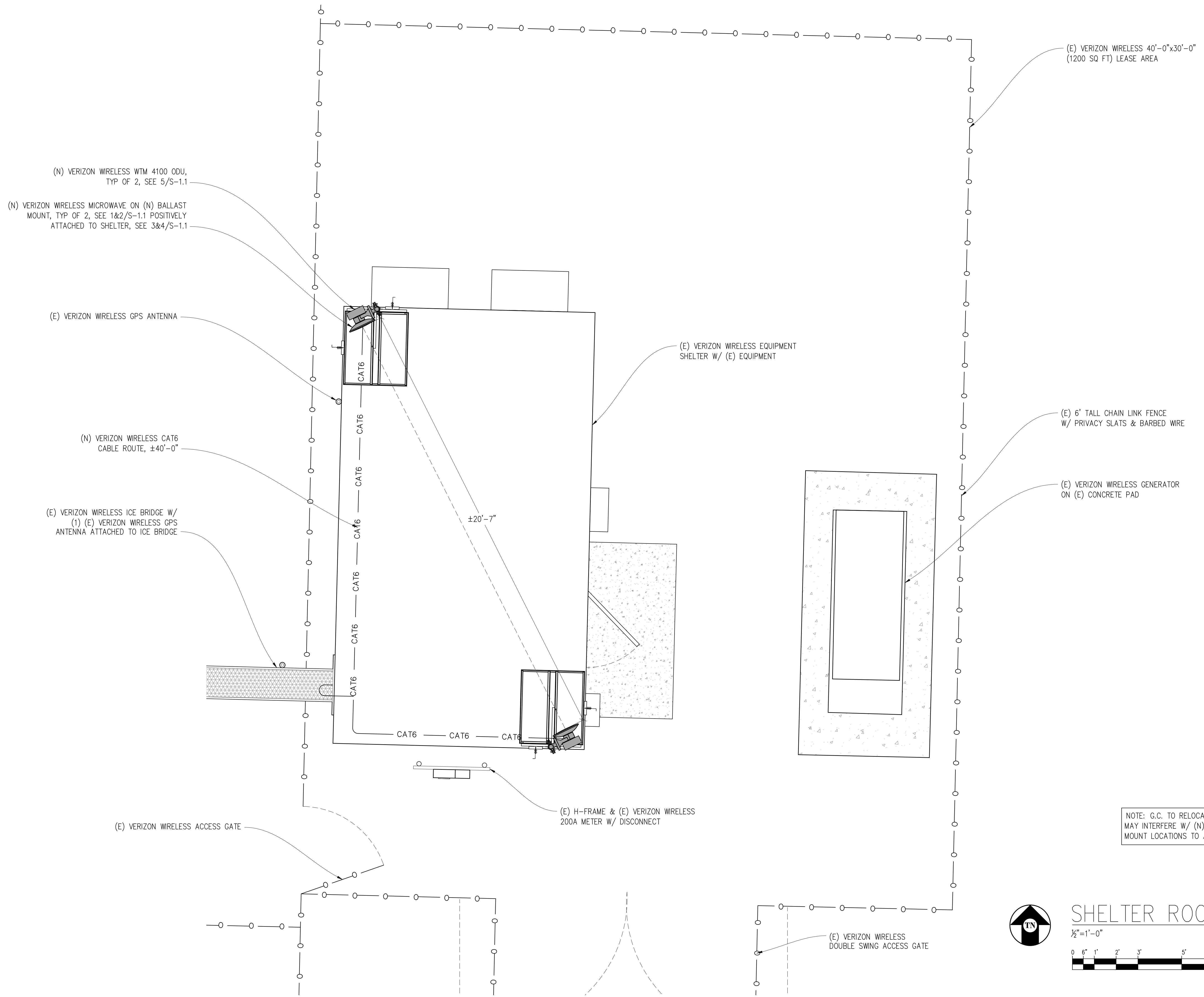

(E) VERIZON WIRELESS 40'-0"x30'-0"
(1200 SQ FT) LEASE AREA

(N) VERIZON WIRELESS WTM 4100 ODU,
TYP OF 2, SEE 5/S-1.1

(N) VERIZON WIRELESS MICROWAVE ON (N) BALLAST
MOUNT, TYP OF 2, SEE 1&2/S-1.1 POSITIVELY
ATTACHED TO SHELTER, SEE 3&4/S-1.1

(E) VERIZON WIRELESS GPS ANTENNA

(N) VERIZON WIRELESS CAT6
CABLE ROUTE, ±40'-0"

(E) VERIZON WIRELESS ICE BRIDGE W/
(1) (E) VERIZON WIRELESS GPS
ANTENNA ATTACHED TO ICE BRIDGE

(E) VERIZON WIRELESS EQUIPMENT
SHELTER W/ (E) EQUIPMENT

(E) 6' TALL CHAIN LINK FENCE
W/ PRIVACY SLATS & BARBED WIRE

(E) VERIZON WIRELESS GENERATOR
ON (E) CONCRETE PAD

(E) H-FRAME & (E) VERIZON WIRELESS
200A METER W/ DISCONNECT

(E) VERIZON WIRELESS ACCESS GATE

(E) VERIZON WIRELESS
DOUBLE SWING ACCESS GATE

NOTE: G.C. TO RELOCATE (E) GPS OR OTHER ITEMS THAT
MAY INTERFERE W/ (N) BALLAST MOUNT OR ADJUST
MOUNT LOCATIONS TO AVOID (E) EQUIPMENT TYP.

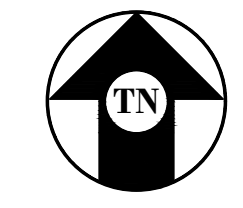

SHELTER ROOF PLAN

1/2"=1'-0"

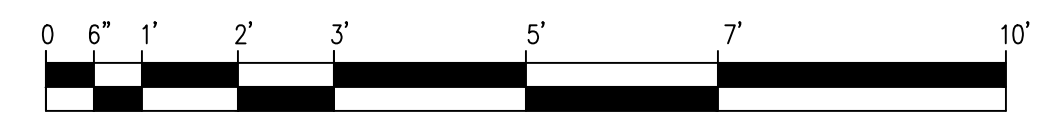

Issued For:
CARSON CITY AIRPORT
2600 E COLLEGE PARKWAY
CARSON CITY, NV 89706

PREPARED FOR
verizon
2770 SHADELANDS DR, BLDG 11
WALNUT CREEK, CA 94598

Vendor:
EPIC
WIRELESS GROUP LLC
Connecting a Wireless World

MDG LOCATION ID: 5000246353
PROJECT NO: 17556403
DRAWN BY: J. ZHAR
CHECKED BY: K. SORENSEN
APPROVED BY: J. SPORE

ISSUE STATUS			
REV	DATE	DESCRIPTION	CAD
1	02/04/26	CD 100%	A.M.
0	01/28/26	CD 90%	J.Z.

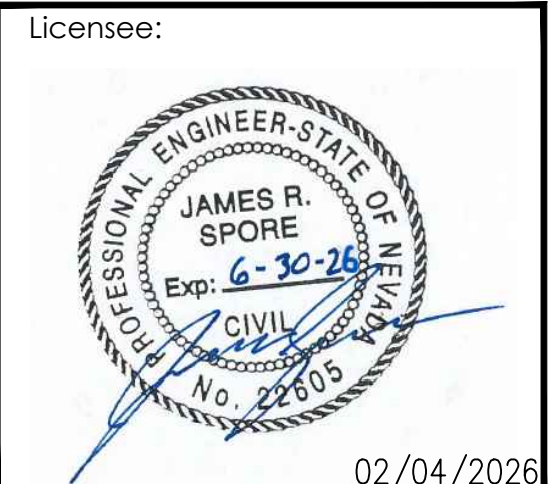

IT IS A VIOLATION OF LAW FOR ANY PERSON,
UNLESS THEY ARE ACTING UNDER THE
DIRECTION OF A LICENSED PROFESSIONAL
ENGINEER, TO ALTER THIS DOCUMENT.

ENGINEER:
Streamline Engineering
3843 Taylor Road, Suite A, Lovins, CA 94650
Contact: Kevin Sorenson Phone: 916-660-1930
E-Mail: kevin@streamlineeng.com Fax: 916-660-1941
THESE PLANS AND SPECIFICATIONS ARE INSTRUMENTS OF SERVICE AND SHALL REMAIN THE PROPERTY OF STREAMLINE ENGINEERING. NO PART OF THESE PLANS OR SPECIFICATIONS SHALL BE REPRODUCED OR TRANSMITTED IN ANY FORM OR BY ANY MEANS, ELECTRONIC OR MECHANICAL, INCLUDING PHOTOCOPYING, RECORDING, OR BY ANY INFORMATION STORAGE AND RETRIEVAL SYSTEM, WITHOUT THE WRITTEN PERMISSION OF STREAMLINE ENGINEERING AND DESIGN INC. ALL RIGHTS RESERVED.

SHEET TITLE:
SHELTER ROOF PLAN

SHEET NUMBER:
A-2.1

Issued For:
CARSON CITY AIRPORT
 2600 E COLLEGE PARKWAY
 CARSON CITY, NV 89706

PREPARED FOR

 2770 SHADELANDS DR, BLDG 11
 WALNUT CREEK, CA 94598

Vendor:

 Connecting a Wireless World

MDG LOCATION ID: 5000246353
 PROJECT NO: 17556403
 DRAWN BY: J. ZHAR
 CHECKED BY: K. SORENSEN
 APPROVED BY: J. SPORE

ISSUE STATUS			
REV	DATE	DESCRIPTION	CAD
1	02/04/26	CD 100%	A.M.
0	01/28/26	CD 90%	J.Z.

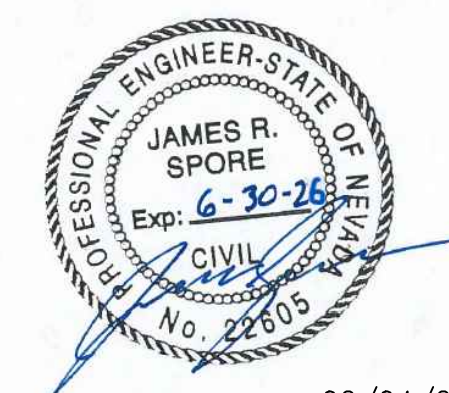
Licensee:

 02/04/2026

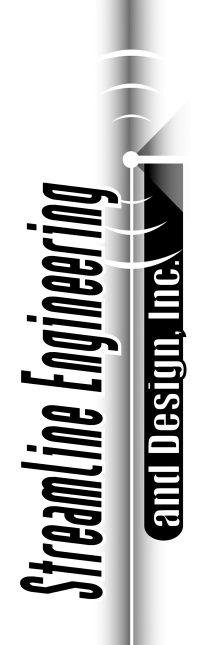
IT IS A VIOLATION OF LAW FOR ANY PERSON, UNLESS THEY ARE ACTING UNDER THE DIRECTION OF A LICENSED PROFESSIONAL ENGINEER, TO ALTER THIS DOCUMENT.

ENGINEER:

 3843 Taylor Road, Suite A, Lincoln, CA 95650
 Contact: Kevin Sorenson Phone: 916-660-1930
 E-Mail: kevin@streamlineeng.com Fax: 916-660-1941
THESE PLANS AND SPECIFICATIONS AS INSTRUMENTS OF SERVICE ARE AND SHALL REMAIN THE PROPERTY OF STREAMLINE ENGINEERING AND DESIGN, INC. THESE PLANS AND SPECIFICATIONS SHALL NOT BE REPRODUCED OR TRANSMITTED IN ANY FORM OR BY ANY MEANS, ELECTRONIC OR MECHANICAL, INCLUDING PHOTOCOPYING, RECORDING, OR BY ANY INFORMATION STORAGE AND RETRIEVAL SYSTEM, WITHOUT THE WRITTEN PERMISSION OF STREAMLINE ENGINEERING AND DESIGN, INC. ALL RIGHTS RESERVED.

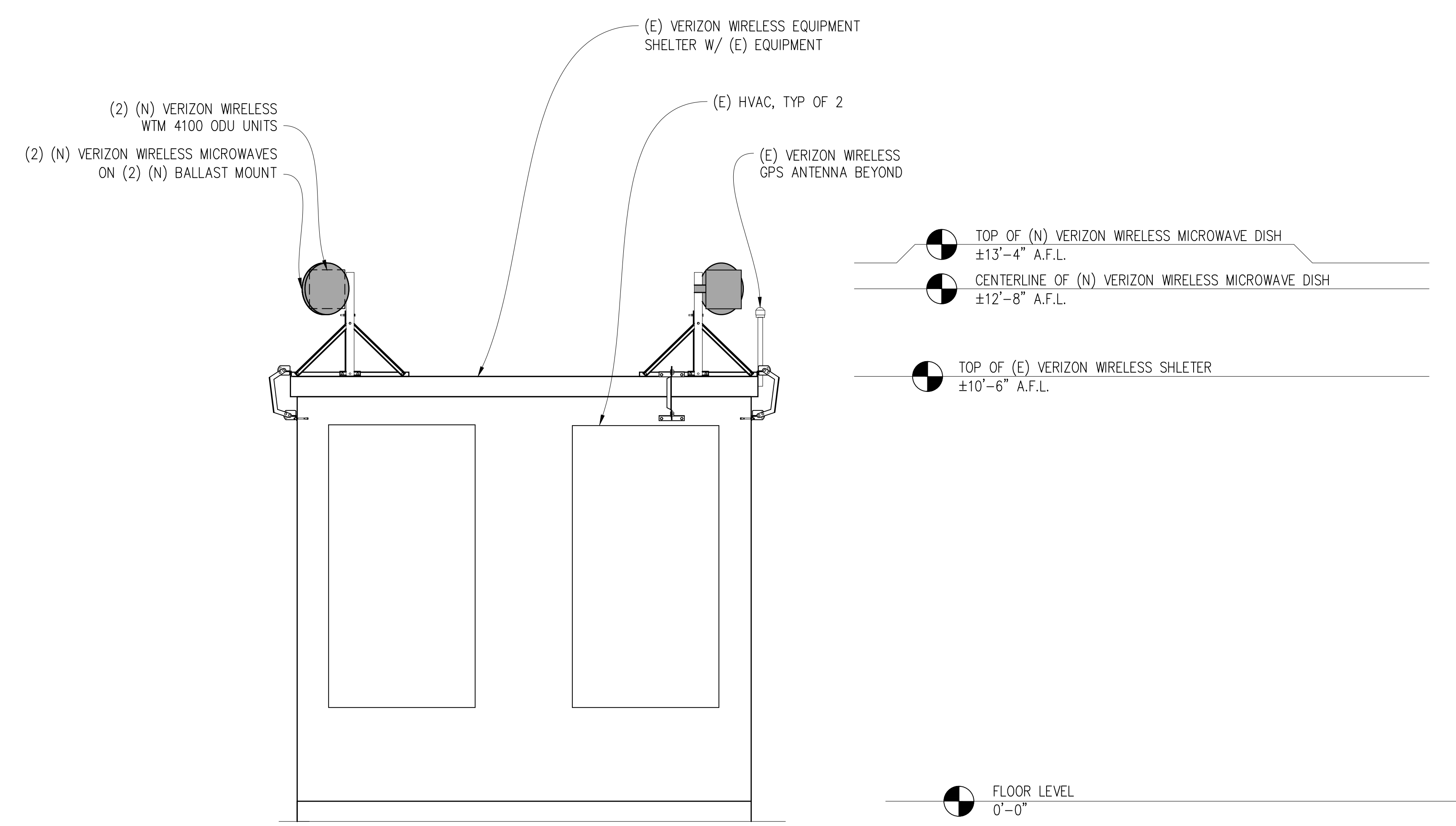
SHEET TITLE:
ELEVATIONS

SHEET NUMBER:
A-3.1

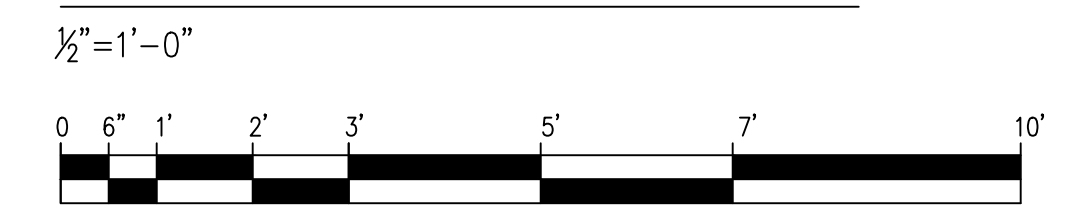

NORTH ELEVATION



NOTE: G.C. TO RELOCATE (E) GPS OR OTHER ITEMS THAT MAY INTERFERE W/ (N) BALLAST MOUNT OR ADJUST MOUNT LOCATIONS TO AVOID (E) EQUIPMENT TYP.

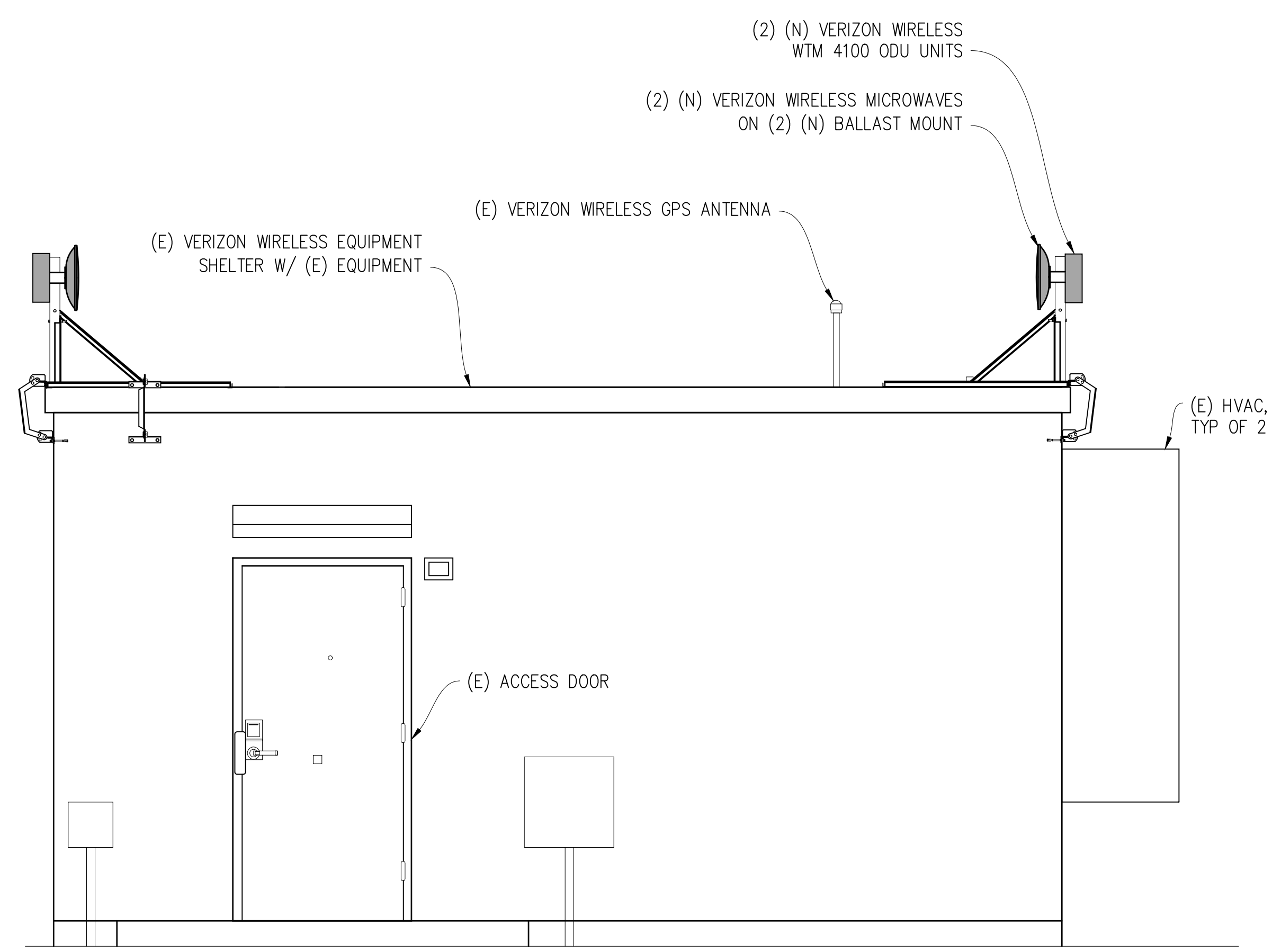

EAST ELEVATION

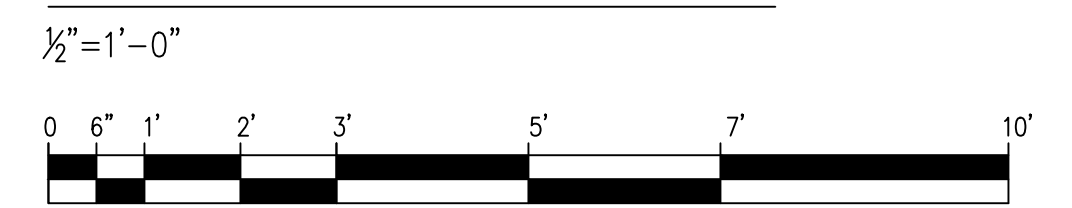

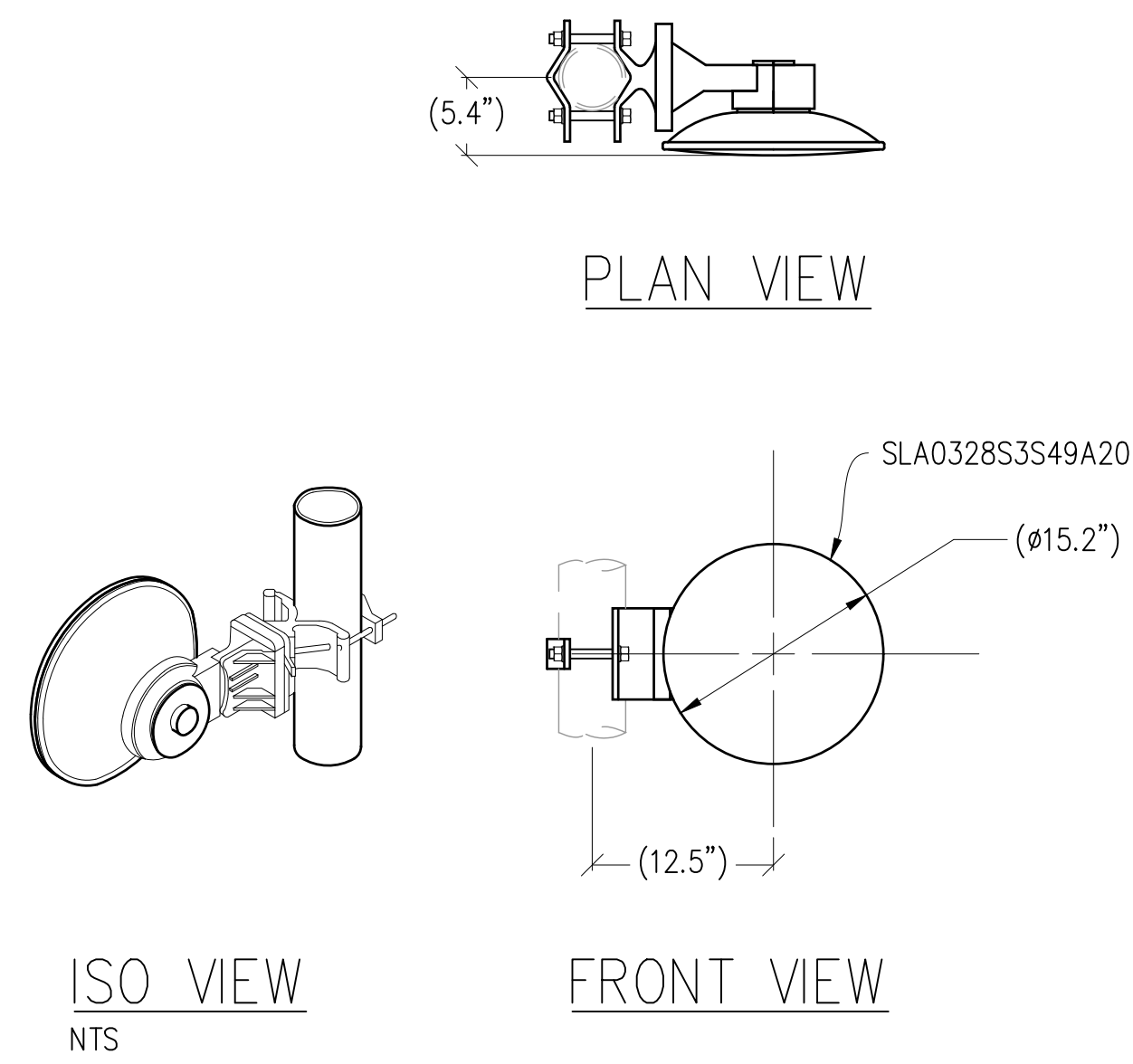

1 MICROWAVE DETAIL
1"=1'-0"

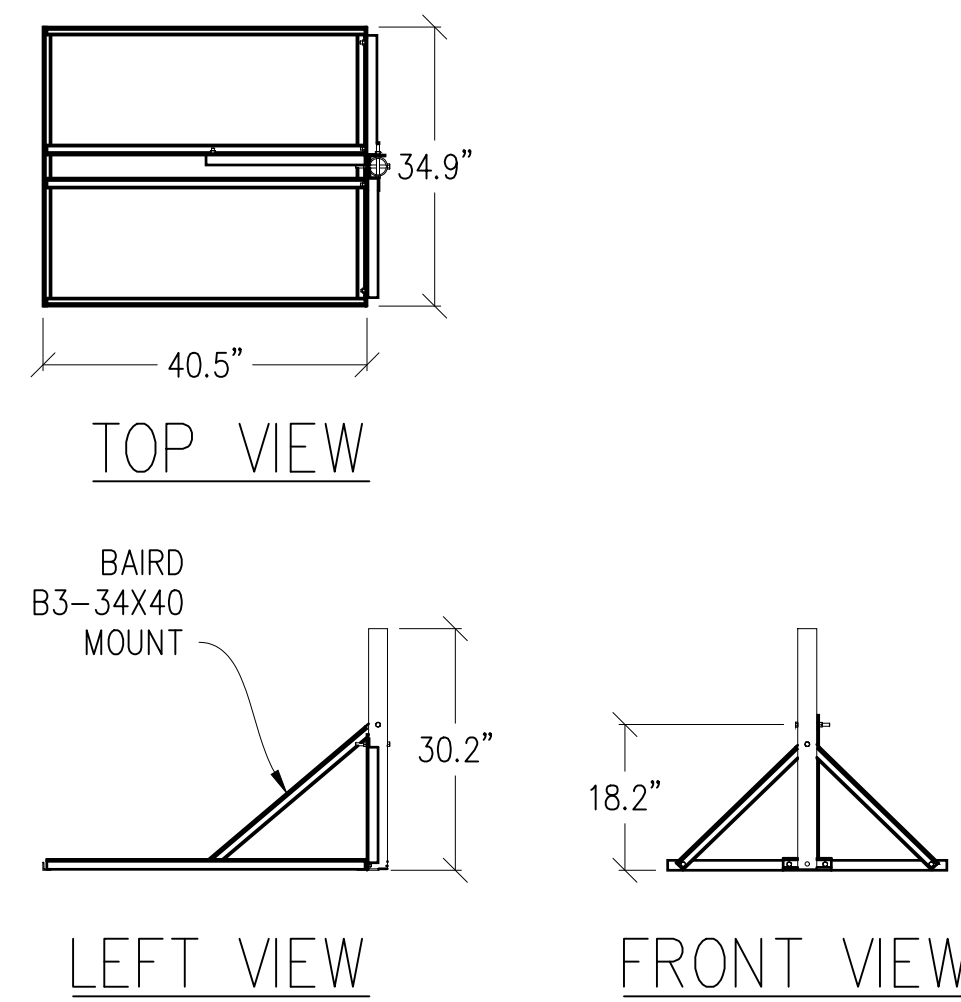

2 MICROWAVE MOUNT DETAIL
1/2"=1'-0"

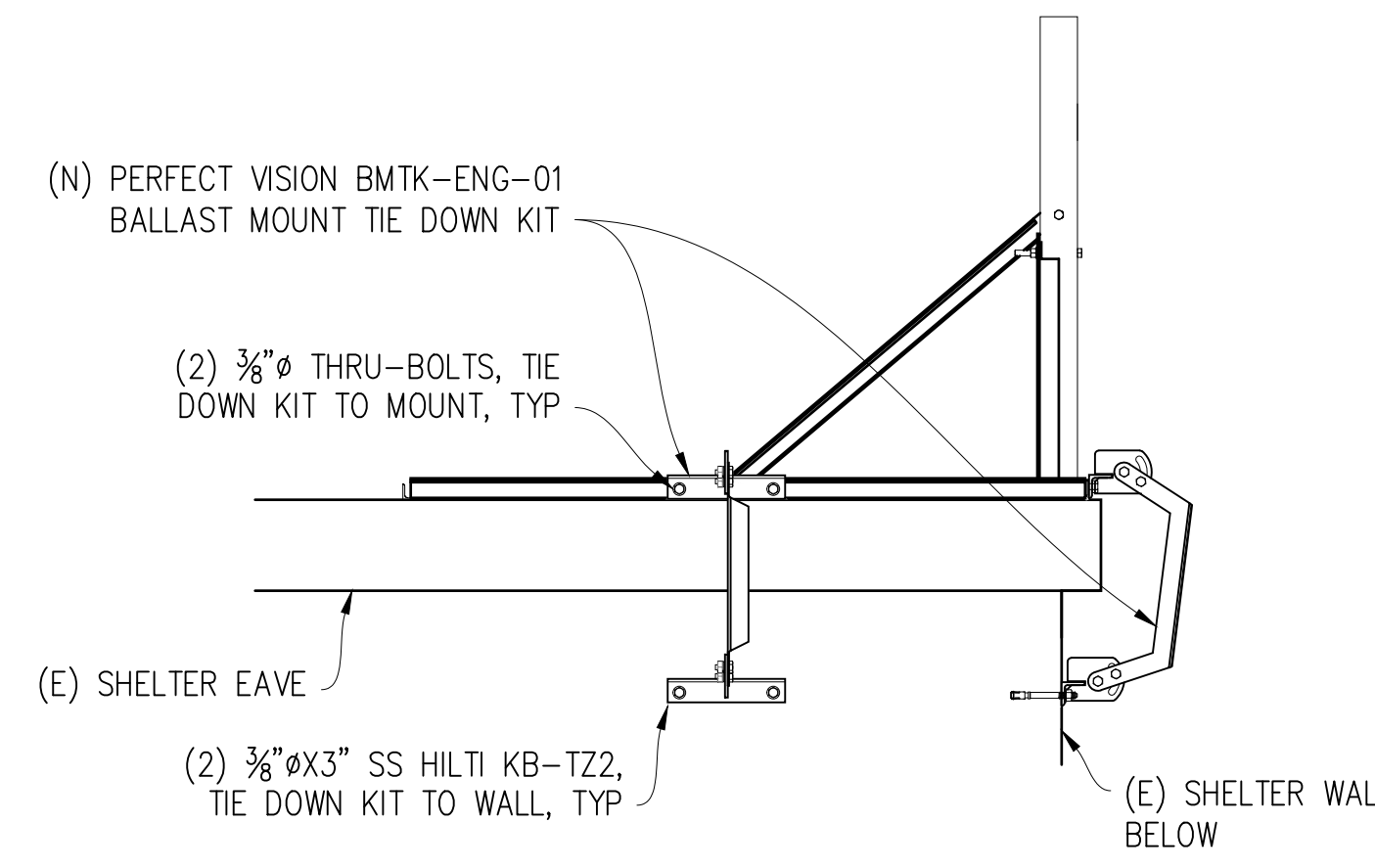

3 ELEVATION VIEW
MOUNT DETAIL
1"=1'-0"

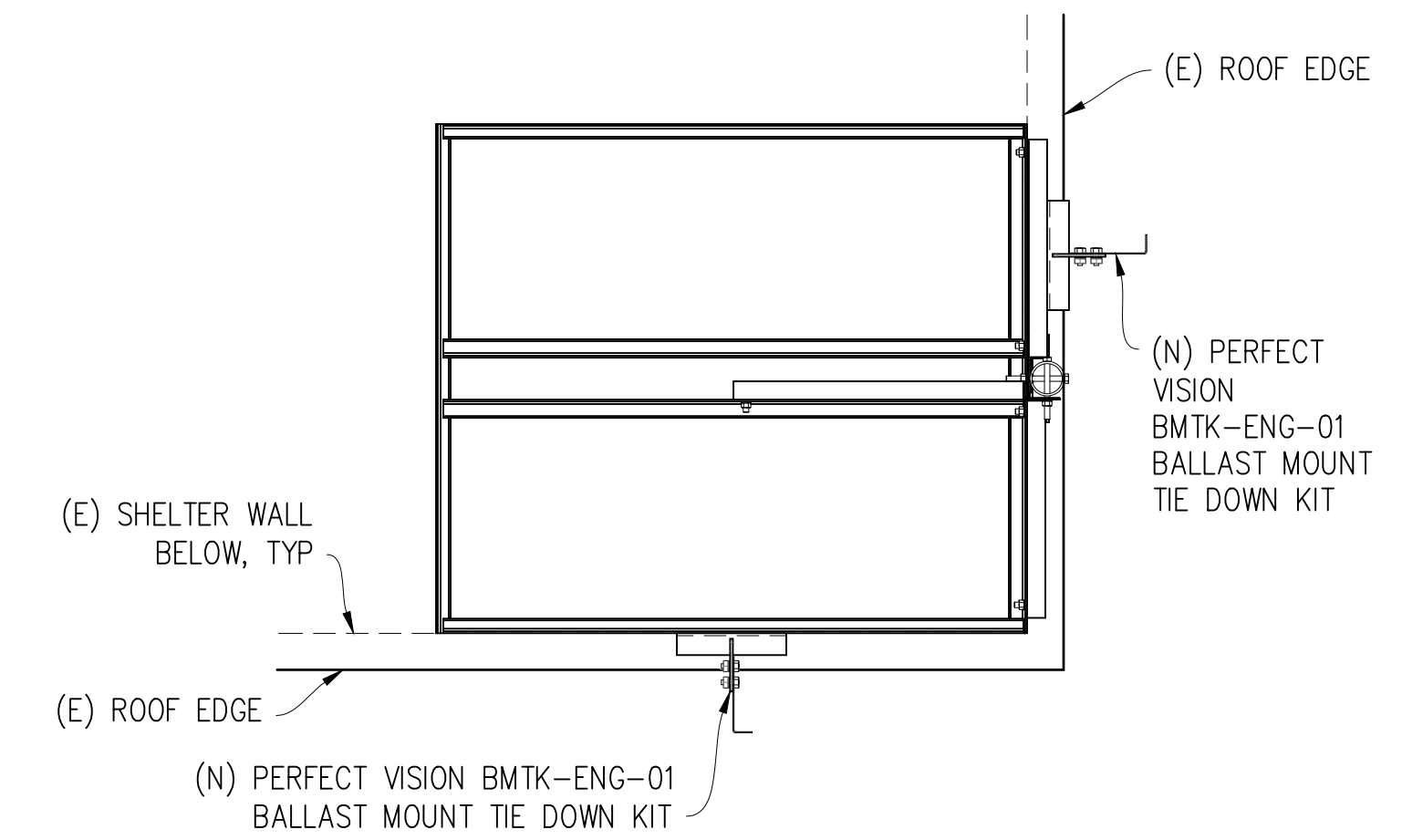

4 PLAN VIEW
MOUNT DETAIL
1"=1'-0"

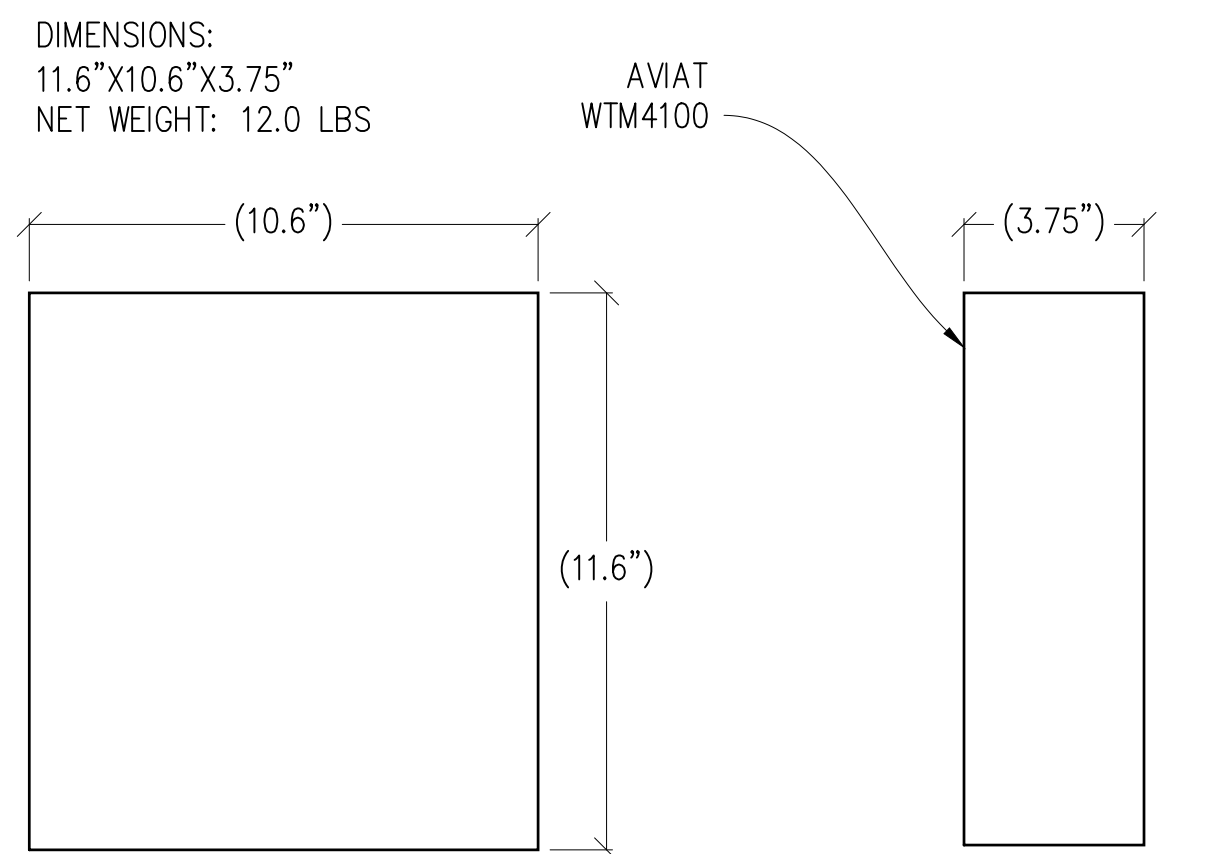

5 ODU DETAIL
3"=1'-0" MAX WEIGHT: 12.0 LBS

Aviat NETWORKS

WTM 4000
ALL-OUTDOOR, IP/SDN RADIO
DATASHEET [ANSI]

Mechanical and Environmental		
Operating temperature	Guaranteed	-27° to +131°F [-33° to +55°C]
	Extended	-49° to +149°F [-45° to +65°C]
Humidity	Guaranteed	0 to 100%, non-condensing
Altitude	Guaranteed	14,763 ft (4500 m)
Input voltage	-20 to -57 V	WTM 4100/ 4200 13-42 GHz
	-40 to -57 V	WTM 4200 5-11 GHz
Power over Ethernet		PoE++ [proprietary]
Power consumption	WTM 4100	50 W nominal, 65 W maximum
	WTM 4200	75-90 W nominal, 108 W maximum
Size (h-w-d), including built-in coupler/OMT		11.6 in x 10.6 in x 3.75 in [295 mm x 270 mm x 95 mm]
Weight, including coupler/OMT	WTM 4100	12 lb [5.5 kg]
	WTM 4200	24 lb [11 kg]

Standards Compliance		
Security	FIPS 197, Cert #A980	
EMC	EN 301 489-1	
	EN 301 489-4	
Operation	EN 300 019 Class 4.1	
Safety	IEC/EN 60950-1	
	IEC/EN 62368-1	
	IEC/EN 62368-3	
	IEC/EN 60950-22	
RF performance	EN 302 217-2	
Water ingress	IEC 60529, IP66	
Lightning protection [internal]	IEC-61000-4-5	

Notes:
 (1) To be confirmed in a later release

Disclaimer
 This material is for informational purposes only and does not constitute a legal obligation to deliver any product, feature or functionality and should not be relied upon in making purchasing decisions. All specifications are guaranteed values, at room temperature (68 to 86°F, 20 to 30°C), referenced to the ACU antenna port (including ACU losses) unless otherwise stated, and are subject to change without notice. The development, release and timing of any features or functionality described for our products is at Aviat Networks' sole discretion. For details of availability, please contact your Aviat Networks Sales Representative.

Aviat, Aviat Networks and the Aviat logo are trademarks or registered trademarks of Aviat Networks, Inc. Copyright © Aviat Networks, Inc. (2022) All Rights Reserved. Data subject to change without notice.
 2022-AUG-01 | 20-AS-WTM4000-ANSI.F | 4/8 | WWW.AVIATNETWORKS.COM

PV-BMTK
BALLAST MOUNT TIE DOWN KIT

REV	DESCRIPTION	DATE	BY	CHKD	APPD
0	PRELIMINARY	1/26/23			
1					
2					
3					
4					

MAXIMUM OFFSET RANGES

REV	DESCRIPTION	DATE	BY	CHKD	APPD
0	PRELIMINARY	1/26/23			
1					
2					
3					
4					

PROPRIETARY AND CONFIDENTIAL THE INFORMATION CONTAINED IN THIS DRAWING IS THE SOLE PROPERTY OF PERFECT VISION. ANY REPRODUCTION IN PART OR AS A WHOLE WITHOUT THE WRITTEN PERMISSION OF PERFECT VISION IS PROHIBITED.

6 BALLAST MOUNT TIE DOWN KIT

Issued For:
CARSON CITY AIRPORT
 2600 E COLLEGE PARKWAY
 CARSON CITY, NV 89706

PREPARED FOR

 2770 SHADELANDS DR, BLDG 11
 WALNUT CREEK, CA 94598

Vendor:

 Connecting a Wireless World

MDG LOCATION ID: 5000246353
 PROJECT NO: 17556403
 DRAWN BY: J. ZHAR
 CHECKED BY: K. SORENSEN
 APPROVED BY: J. SPORE

ISSUE STATUS			
REV	DATE	DESCRIPTION	CAD
1	02/04/26	CD 100%	A.M.
0	01/28/26	CD 90%	J.Z.

Licensee:

 02/04/2026
 IT IS A VIOLATION OF LAW FOR ANY PERSON, UNLESS THEY ARE ACTING UNDER THE DIRECTION OF A LICENSED PROFESSIONAL ENGINEER, TO ALTER THIS DOCUMENT.

ENGINEER:

 3843 Taylor Road, Suite A, Lovins, CA 94650
 Contact: Kevin Sorenson Phone: 916-660-1930
 E-Mail: kevin@streamlineeng.com Fax: 916-660-1941
THIS PLAN AND SPECIFICATIONS ARE INSTRUMENTS OF SERVICE AND SHALL REMAIN THE PROPERTY OF STREAMLINE ENGINEERING AND SHALL NOT BE REPRODUCED OR COPIED IN ANY MANNER WITHOUT THE WRITTEN PERMISSION OF STREAMLINE ENGINEERING. ALL RIGHTS RESERVED.

SHEET TITLE:
DETAILS

SHEET NUMBER:
S-1.1



FlyCarsonCity.com

CCAA BOARD MEMO

Agenda Item: H-1

BOARD MEMO 2026-04

Meeting Date: March 18, 2026

Agenda Title: FOR DISCUSSION AND POSSIBLE ACTION: Review and Approve the FY 2026/2027 Preliminary Budget for submission to the Nevada Department of Taxation (C. Jenkins, J. Sutton).

Staff Summary: This is the review of the FY 2026/2027 Preliminary Budget. NRS statutes require that a preliminary budget must be approved and submitted to the Nevada Department of Taxation no later than April 15, 2026.

Agenda Action: Motion and Approval

Time Requested: 15 Minutes

Proposed Motion

I move to approve the FY 2026/2027 Preliminary Budget and direct staff to submit to the Nevada Department of Taxation.

CCAA’S Strategic Goal

Maintain airport infrastructure in top condition.
Maintain financial stability.

Previous Action and Executive Summary

The Preliminary Budget is approved and submitted to the Nevada Department of Taxation Annually.

Financial Information

Is there a fiscal impact?

X No Yes

If yes, account name/number & amount: N/A

Is it currently budgeted?

N/A

Alternatives

N/A

Board Action Taken:

Motion: _____

1) _____

2) _____

Aye/Nay

(Vote Recorded)

CCAA 26/27 Preliminary Budget Worksheet

	FY 24/25	FY 24/25	FY 25/26	FY 25/26	FY 26/27	FY 26/27
	Budget	Actual	Budget	Projected Actual	Budget	Notes
INCOME						
5010 - REAL/PERSONAL PROPERTY TAX						
5010.1 - Aircraft	210,000.00	193,943.55	205,000.00	193,945.68	225,500.00	When the new hangars have aircraft in them, this will increase
5010.2 - Building	155,000.00	158,681.01	145,000.00	158,682.84	162,000.00	New hangars under construction
SUB-TOTAL 5010 - REAL/PERSONAL PROPERTY TAX	365,000.00	352,624.56	350,000.00	352,628.52	387,500.00	
5050 - AIRPORT LEASES						
5050H - Hangar Lease	79,100.00	72,720.00	73,000.00	73,440.00	75,643.20	3% increase
5051 - Land Leases	245,000.00	269,041.29	320,000.00	329,943.84	349,943.84	Additional \$20,000 for new ground lease and CPI
5052 - Tower Leases	73,353.19	71,000.00	84,500.00	75,068.04	77,320.08	3% Annual increase
5053 - Lease-Mayes	6,240.00	6,240.00	6,240.00	6,240.00	6,240.00	
5056 - Lease-Gonzalez	0.00	7,258.00	7,258.00	7,258.00	7,258.00	
5054 - Through The Fence Property Tax Offset	(140,966.00)	0.00	-9,000.00	-9,000.00	-9,000.00	
SUB-TOTAL 5050 - AIRPORT LEASES	262,727.19	426,259.29	481,998.00	482,949.88	507,405.12	
5150 - Tie Down Fees	12,155.12	9,000.00	12,500.00	14,782.44	15,000.00	CPI Increase
5151 - Gate Card Fees	3,614.65	900.00	1,500.00	5,545.64	3,000.00	Likely not as high as 25/26, but should be higher than years past.
5155 - Parking Fees	0.00	200.00	500.00	0.00	200.00	Lower because not charging for overnight vehicle parking for monthly tie down customers
5200 - Fuel Flowage Fees	20,243.69	20,000.00	24,000.00	25,116.26	26,000.00	
5201 - Jet Fuel Tax	2,553.68	4,000.00	3,000.00	3,169.44	3,500.00	
5250 - Through the Fence Fees	0.00	7,200.00	9,750.00	750.00	750.00	We only get \$750 per year
5300 - Class II FBO Fees	5,400.00	12,000.00	8,000.00	5,400.00	7,200.00	Increase by at least 1 Class II FBO
5402 - Open House Income	7,700.00	10,000.00	10,000.00	22,800.00	15,000.00	Expect more participation after the success of last year
5404 - Rock Materials Sales	67,338.15	40,000.00	75,000.00	33,309.48	35,000.00	Reduced rock sales this year
5500 - Interest Income	450,913.31	65,000.00	800,000.00	32,591.90	33,000.00	
5998 - Terminal Rental	500.00	500.00	400.00	0.00	200.00	
SUB-TOTAL FEES & MISC INCOME	570,418.60	168,800.00	944,650.00	143,465.16	138,850.00	
TOTAL INCOME	1,198,145.79	947,683.85	1,776,648.00	979,043.56	1,033,755.12	
OPERATING EXPENSES						
MISCELLANEOUS OPERATION EXPENSES						
6000 - Airport Engineering	0.00	10,100.00	3,000.00	0.00	3,000.00	
6169 - Taxes and Licenses	300.00	200.00	300.00	168.00	200.00	
6130 - Dues	2,300.00	720.00	1,200.00	520.00	0.00	Consolidate with Memberships
6135 - Memberships	500.00	100.00	250.00	250.00	1,500.00	
6136 - Registration	0.00	0.00	0.00	0.00	0.00	Consolidate with Conferences
6137 - Conferences	4,500.00	5,250.64	2,500.00	2,500.00	4,500.00	
6170 - SWAAAE Travel	850.00	0.00	1,500.00	1,500.00	0.00	Consolidate with Travel
6190 - Office Expense PC Software	2,000.00	1,324.26	800.00	445.00	1,500.00	
6200 - Office Expense PC Hardware	500.00	255.64	1,250.00	1,328.28	1,500.00	
6211 - Meals and Entertainment	750.00	930.16	2,200.00	2,200.00	2,200.00	To enable the airport to spend money on meals for business reasons
6218 - Marketing and Website	2,500.00	6,927.90	6,000.00	1,630.16	5,000.00	
6369 - Travel	500.00	272.43	2,000.00	2,000.00	5,000.00	
6280 - Open House Expense	12,000.00	7,691.21	12,000.00	23,000.00	15,000.00	
SUB-TOTAL 6000-6280 - MISC OPERATING EXPENSES	26,700.00	33,772.24	33,000.00	35,541.44	39,400.00	
UTILITIES						
6238 - Stormwater Discharge Permit	0.00	1,000.00	1,000.00	1,000.00	1,000.00	
6302 - Phone & Internet	5,000.00	6,174.26	6,500.00	5,400.00	6,500.00	New connection at SRE building
6303 - Electric	19,000.00	12,507.64	19,000.00	8,949.98	12,000.00	SRE Building
6304 - Gas	1,000.00	865.81	1,500.00	410.00	1,200.00	SRE Building
6305 - Water	2,300.00	2,653.47	2,500.00	2,308.00	2,800.00	SRE Building
6306 - Carson City Landfill	1,200.00	1,587.76	1,300.00	703.76	1,000.00	New Dumpster is reducing cost
SUB-TOTAL 6301 - UTILITIES	28,500.00	24,788.94	30,800.00	17,771.74	23,500.00	
OTHER EXPENSES						
6308 - Office Expenses and Supplies	1,500.00	1,350.08	1,750.00	2,478.64	2,500.00	
6309 - Legal	100,000.00	64,025.60	100,000.00	26,300.00	80,000.00	
6310 - Security	4,000.00	4,579.88	6,400.00	3,390.00	6,400.00	Increased Rates
6311 - CCAA Printing	500.00	371.09	500.00	0.00	500.00	
6312 - Data Storage	550.00	663.53	500.00	780.00	800.00	Increased Rates
6313 - Insurance	13,000.00	21,389.69	15,000.00	22,000.00	22,000.00	
6314 - Auditing	42,000.00	27,876.25	40,000.00	40,000.00	40,000.00	
6314a - Bookkeeping (Bullis)	16,000.00	25,347.00	25,000.00	32,854.00	33,000.00	
6314b - Accounting/TMCDBooks	0.00	0.00	0.00	0.00	0.00	
6315 - Contract Services/Appraisal	14,000.00	10,500.00	7,000.00	9,680.00	10,000.00	
6316 - Bank/Square Charges	400.00	925.42	1,000.00	1,191.72	1,200.00	
6317 - Airport Equipment Maintenance	15,000.00	18,305.59	18,000.00	12,000.00	15,000.00	
6325 US Bank (Tractor)	0.00	0.00	0.00	0.00	0.00	
6317.5 - AWOS III Service Expense	7,000.00	5,936.00	7,000.00	7,000.00	7,000.00	Relocate AWOS from terminal to SRE building
6318 - Facility Maintenance	8,000.00	11,638.23	20,000.00	9,100.78	15,000.00	
6319 - Airfield Maintenance	40,000.00	21,513.07	40,000.00	40,000.00	40,000.00	Will spend the full budget for SRE building tools and equipment.
6319.5 - Gate maintenance	2,000.00	1,139.17	2,000.00	2,464.82	3,000.00	Purchase some important spare parts
6319.51 - Depreciation Expense	140,000.00	0.00	140,000.00	140,000.00	140,000.00	
SUB-TOTAL 6300 OTHER EXPENSES	403,950.00	215,560.60	424,150.00	349,239.96	416,400.00	

	LABOR EXPENSE					
	6351 - Salaries	292,000.00	283,001.80	299,000.00	265,049.98	326,550.00
	6351.5 - Overtime Budget (Airfield)	2,500.00	0.00	2,000.00	585.10	2,000.00
	6352 - Healthcare	56,250.00	59,044.05	66,000.00	58,000.00	66,000.00
	6353 - PERS Retirement Contribution	84,000.00	112,373.88	100,165.00	110,000.00	109,394.25
	6354 - Nevada Payroll	1,200.00	1,498.00	1,500.00	1,522.00	1,600.00
	6355 - Workers Compensation	5,325.00	4,061.87	8,360.00	3,241.30	4,000.00
	6356 - State Unemployment Contribution	2,870.00	0.00	2,950.00	2,950.00	3,383.65
	6476 - Uniforms	1,500.00	1,174.63	1,200.00	1,091.28	1,200.00
	SUB-TOTAL 6350 - LABOR EXPENSE	445,645.00	461,154.23	481,175.00	442,439.66	514,127.90
TOTAL OPERATING EXPENSE		904,795.00	735,276.01	969,125.00	844,992.80	993,427.90
NET OPERATING INCOME		293,350.79	212,407.84	807,523.00	134,050.76	40,327.22
FAA AIP GRANT FUNDED PROJECTS						
	6035.1 - AIP #44 Construct SRE Bldg. (40' X 80') Revenue	840,625.00	28,287.02	419,890.00	1,090,073.00	0.00
	6035.2 - AIP #44 Construct SRE Bldg. (40' X 80') Expense	-750,000.00	-28,516.72	-343,746.00	-1,288,542.94	0.00
	6036.1 - AIP #37 Acquire Snow Removal Equipment Revenue	216,000.00	196,583.76	0.00	0.00	0.00
	6036.2 - AIP #37 Acquire Snow Removal Equipment Expense	-216,000.00	-196,583.76	0.00	0.00	0.00
	6042.1 - AIP #43 Approach Lighting (Phase 3)(Const PAPI) Revenue	0.00	311,373.57	976,654.00	1,258.00	0.00
	6042.2 - AIP #43 Approach Lighting (Phase 3)(Const PAPI) Expense	0.00	-332,131.82	-1,000,000.00	-21,327.00	0.00
	6044.1 - AIP #46 - Drainage Improvements Design Revenue	140,625.00	0.00	140,625.00	100,225.00	0.00
	6044.2 - AIP #46 - Drainage Improvements Design Expense	-150,000.00	0.00	-150,000.00	-105,500.00	0.00
	AIP #48 - Aviation Demand Forecast Update Revenue	0.00	0.00	148,635.00	3,325.00	0.00
	AIP #48 - Aviation Demand Forecast Update Expense	0.00	0.00	-156,457.89	-570.00	0.00
	AIP #47 Apron Rehab Project Revenue	0.00	0.00	305,000.00	19,073.63	0.00
	AIP #47 Apron Rehab Project Expense	0.00	0.00	-320,250.00	-37,455.00	0.00
	Extend Rwy 9/27 Environmental Assessment Revenue	0.00	0.00	0.00	0.00	247,000.00
	Extend Rwy 9/27 Environmental Assessment Expense	0.00	0.00	0.00	0.00	-259,350.00
	Extend Rwy 9/27 25% Design Revenue	0.00	0.00	0.00	0.00	341,000.00
	Extend Rwy 9/27 25% Design Expense	0.00	0.00	0.00	0.00	-358,050.00
	Taxiway B Reconstruction Revenue	0.00	0.00	0.00	0.00	2,610,000.00
	Taxiway B Reconstruction Expense	0.00	0.00	0.00	0.00	-2,740,500.00
	North Apron Pavement Preservation Construction Revenue	0.00	0.00	0.00	0.00	210,000.00
	North Apron Pavement Preservation Construction Expense	0.00	0.00	0.00	0.00	-220,500.00
	Other Capital Outlay	0.00	0.00	0.00	0.00	0.00
TOTAL FAA AIP GRANT REVENUE		1,197,250.00	536,244.35	1,990,804.00	1,213,954.63	3,408,000.00
TOTAL FAA AIP GRANT EXPENSE		-1,116,000.00	-557,232.30	-1,970,453.89	-1,453,394.94	-3,578,400.00
NET FAA AIP GRANT MATCH REQ'D		81,250.00	-20,987.95	20,350.11	-239,440.31	-170,400.00
NET INCOME AFTER GRANT MATCH		374,600.79	191,419.89	827,873.11	-105,389.55	-130,072.78
						Profit of \$18,927.22 excluding depreciation and offset for TTF property tax reduction.
	6414 - Terminal Building Architect Rendering and Environmental	0.00	0.00	0.00		0.00
	6020 - Pavement Maintenance	120,000.00	0.00	300,000.00	250,000.00	198,500.00
TOTAL CCAA CAPITAL PROJECTS		120,000.00	0.00	300,000.00	250,000.00	198,500.00
TOTAL NET INCOME		254,600.79	191,419.89	527,873.11	-355,389.55	-328,572.78



FlyCarsonCity.com

CCAA BOARD MEMO

Agenda Item: H-2

BOARD MEMO 2026-05

Meeting Date: March 18, 2026

Agenda Title: FOR DISCUSSION: Consideration of a pay increase for Airport Manager. (S. Tackes)

Staff Summary: Annual review of Airport Manager. Per Staff/Airport Counsel evaluation, an increase in the Manager's salary is warranted based on a review of comparable regional salaries, the Airport Manager's performance this past year, and increased demands on him from the increase in airport projects.

Agenda Action: Motion and Approval

Time Requested: 15 Minutes

Proposed Motion

N/A

CCAA'S Strategic Goal

Maintain financial stability.
Maintain positive relationships with the community.
Support economic activity in the region.
Provide for the safety and security of airport users.
Maintain airport infrastructure in top condition.

Previous Action and Executive Summary

June 28, 2021 (Item F-1) – Corey Jenkins hired as the Airport Manager.

February 16, 2022 (Item H-1) – Corey Jenkins was determined to meet the requirements set forth in the Offer of Employment.

February 15, 2023 (Item H-3) – A 10% pay increase was granted to Corey Jenkins

February 21, 2024 (Item H-3) – Corey Jenkins was determined to exceed the requirements

set forth in the Offer of Employment and was granted a salary adjustment to be more competitive with the market rate for an Airport Manager.

February 18, 2025 (Item H-3) – Corey was determined to exceed the requirements set forth in the Offer of Employment and was granted a 5% salary increase.

Over the past year, the airport has continued its strong financial performance while maintaining expanded operational coverage. Additional Airport Operations staff continue to support ongoing improvements in maintenance, security, and wildlife hazard mitigation.

Customer service and security efforts have continued to improve with the support of the Airport Administrative Assistant, who manages airport access control and enforces access and driving regulations under the Airport Manager’s direction. These efforts have contributed to a reduction in trespassing incidents and vehicle incursions while allowing the Airport Manager to focus on priorities identified by the Authority.

The Airport Manager remains actively engaged in the local and regional aviation community, resulting in sustained interest in hangar development and overall airport utilization. Multiple developers are currently in discussions to construct additional hangars, supported by their own independent studies confirming strong demand for hangar space at Carson City Airport.

Custom software solutions developed by the Airport Manager, combined with the support of the Airport Administrative Assistant, have provided the data necessary to proceed with hangar use compliance enforcement. The process is currently under legal review.

The FAA has expressed support for a runway extension following outreach efforts to local, state, and federal partners highlighting the operational need to accommodate the safety requirements of increased jet and turboprop activity.

In addition, Carson City has been engaged to initiate the land transfer process outlined in NRS 844. Meetings with the FAA have resulted in their concurrence for transferring airport land to the Airport Authority.

Financial Information

Is there a fiscal impact?

X No Yes

If yes, account name/number & amount: N/A

Is it currently budgeted?

N/A

Alternatives

N/A

Board Action Taken:

Motion: _____

1) _____

2) _____

Aye/Nay

(Vote Recorded)

Airport Manager Salaries @ Comparable Airports

State	City	Airport	Salary Range	Date of Data	Based Aircraft	Annual Operations	Budget	STAFF*
Nevada	Carson City	CXP	\$126,000	2025	399	86,088	\$1,000,000	4
Nevada	Boulder City	BVU	\$106,049 - \$155,891	2025	252	44,521	\$900,000	3
California	Truckee	TRK	\$186,766 - \$274,547	2025	154	35,000	\$18,000,000	27+
Nevada	Reno Stead	RTS	\$118,553 - \$180,200	2025	185	60,000	N/A	N/A
California	South Lake Tahoe	TVL	\$162,760	2026	24	13,863	\$1,800,000	5
Nevada	Elko	EKO	\$111,867	2025	70	34,500	\$41,800,000	6+
Nevada	Minden	MEV	\$104,624 - \$146,494.40	2025	272	90,920	N/A	N/A
Arizona	Sedona	SEZ	\$169,500.00	2026	63	35,000	\$1,800,000	9
Utah	St. George	SGU	\$167,833.09	2023	195	77,158	\$2,875,440	16
Oregon	Bend	BND	\$125,000	2026	226	141,175	\$2,000,000	3

Corey Salary History

Date	Salary	PERS Rate	PERS Contribution
8/4/2021	\$ 78,000.00	31%	\$ 24,180.00
2/4/2022	\$ 81,000.00	31%	\$ 25,110.00
3/1/2023	\$ 97,200.00	31% and 35	\$ 34,020.00
3/1/2024	\$ 120,000.00	35%	\$ 42,000.00
3/1/2025	\$ 126,000.00	35% and 38	\$ 48,510.00

Airport Revenue Over Time

Revenue	2021	2026	Percent Annual Increase	Dollar Amount Increase
Property Tax Revenue	\$ 289,243.00	\$ 352,628.52	18%	\$ 63,385.52
Lease Revenue	\$ 250,635.00	\$ 482,949.88	48%	\$ 232,314.88
Total Income	\$ 539,878.00	\$ 835,578.40	35%	\$ 295,700.40



FlyCarsonCity.com

March 18, 2025

Carson City Airport Manager's Report Prepared by Corey Jenkins

- Work on budget planning with Jim.
 - Jon Rogers has been available for guidance and has helped with the process.

- Working with potential developers for new hangar development.
 - New TTF project north of Delta coming soon.
 - May result in additional applications after the first can be used as model.
 - Will align with the original intention of a hangar in support of a manufacturing operation.
 - Other airport development projects in discussions.

- Multiple Conferences coming up.
 - Washington D.C. government issues conference to promote the need for the runway extension project.
 - Western Nevada Development District (WNDD) annual conference.
 - Will speak on the transportation panel.

- Rick Lee provided the airport operations updates below.
 - Mowing progress update.
 - These are areas of tall brush that has not been previously mowed or areas of high potential to be wildlife attractants.
 - The additional staff and the mild winter have made this possible.
 - Rick and Morgan have completed UNR cooperative extension herbicide applicator license training for continuing education and currency requirements.
 - Morgan completed the AAAE Basic Airport Safety and Operations Specialist school (ASOS).

Fuel Flowage 2026

Total							
	Self-Serve		Full-Service		Total Combined		% Change
Month	100LL	Jet A	100LL	Jet A	Gallons	FFF	Annual Change
January-26	8705	1758	5287	22545	38295	\$ 1,914.76	27%
February-26	0	0	0	0	0	\$ -	-100%
March-26	0	0	0	0	0	\$ -	-100%
April-26	0	0	0	0	0	\$ -	-100%
May-26	0	0	0	0	0	\$ -	-100%
June-26	0	0	0	0	0	\$ -	-100%
July-26	0	0	0	0	0	\$ -	-100%
August-26	0	0	0	0	0	\$ -	-100%
September-26	0	0	0	0	0	\$ -	-100%
October-26	0	0	0	0	0	\$ -	-100%
November-26	0	0	0	0	0	\$ -	-100%
December-26	0	0	0	0	0	\$ -	-100%
Total	8705	1758	5287	22545	38295	\$ 1,914.76	-91%

Aircraft Operations 2026

2026 ADS-B Airport Operations				
Month	Arrivals	Departures	Total Operations	Annual Change
January-26	1467	1527	2994	-18%
February-26	1177	1195	2372	-22%
March-26			0	-100%
April-26			0	-100%
May-26			0	-100%
June-26			0	-100%
July-26			0	-100%
August-26			0	-100%
September-26			0	-100%
October-26			0	-100%
November-26			0	-100%
December-26			0	-100%
Total Annual	2644	2722	5366	-88%

“Triangle” area mowing to reduce wildlife habitat and fire hazard.

Area mowed yearly since 2020 shaded green = 7 Acres

Areas mowed January 26 - February 9, 2026 outlined or shaded red = 5.5 Acres

Total triangle area = 30 Acres

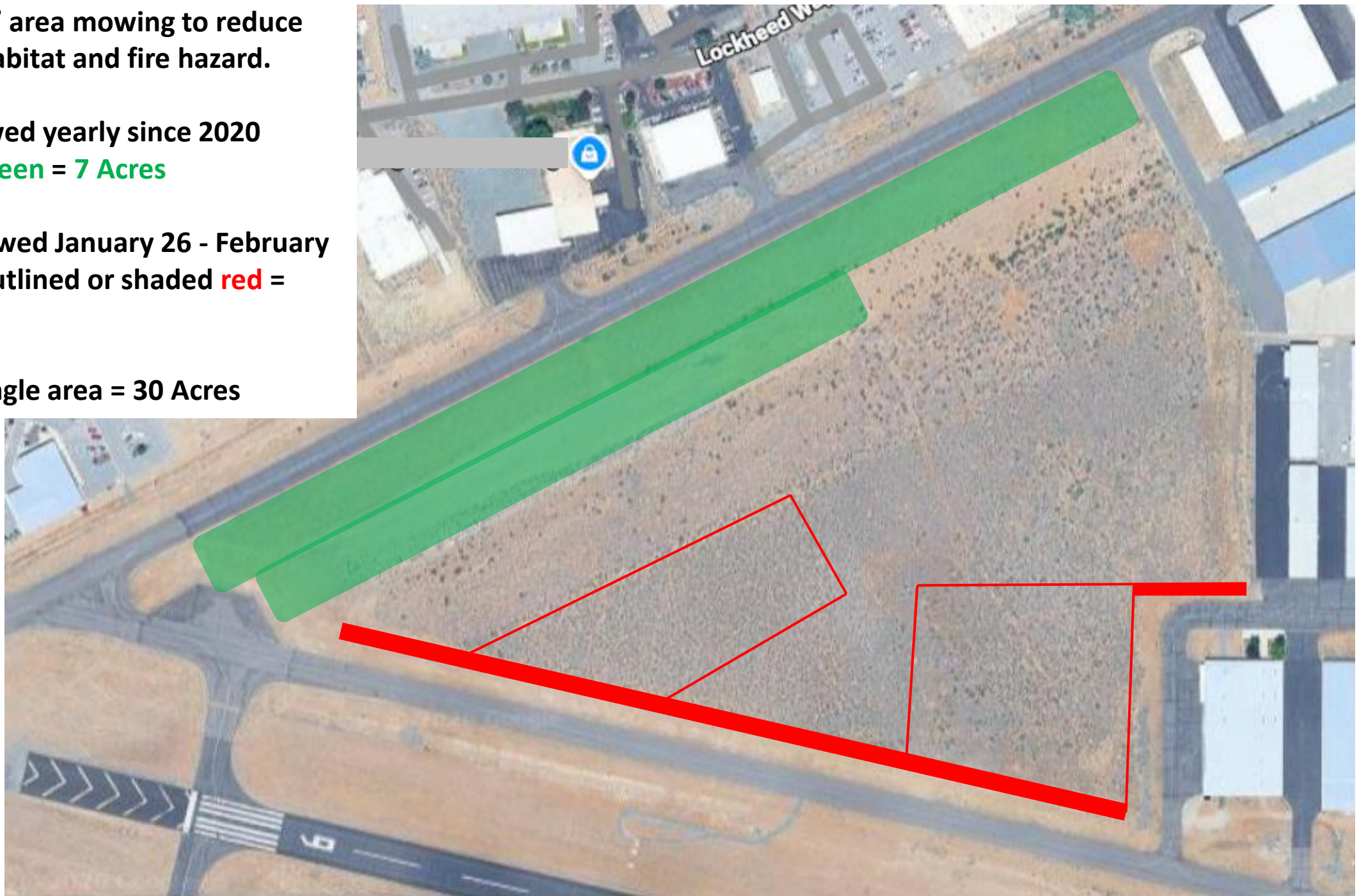

“Triangle” area mowing to reduce wildlife habitat and fire hazard.

Area mowed yearly since 2020 shaded green = 7 Acres

Additional area mowed February 20 – March 6, 2026 to expand outlined red area to 17 Acres

Total triangle area = 30 Acres

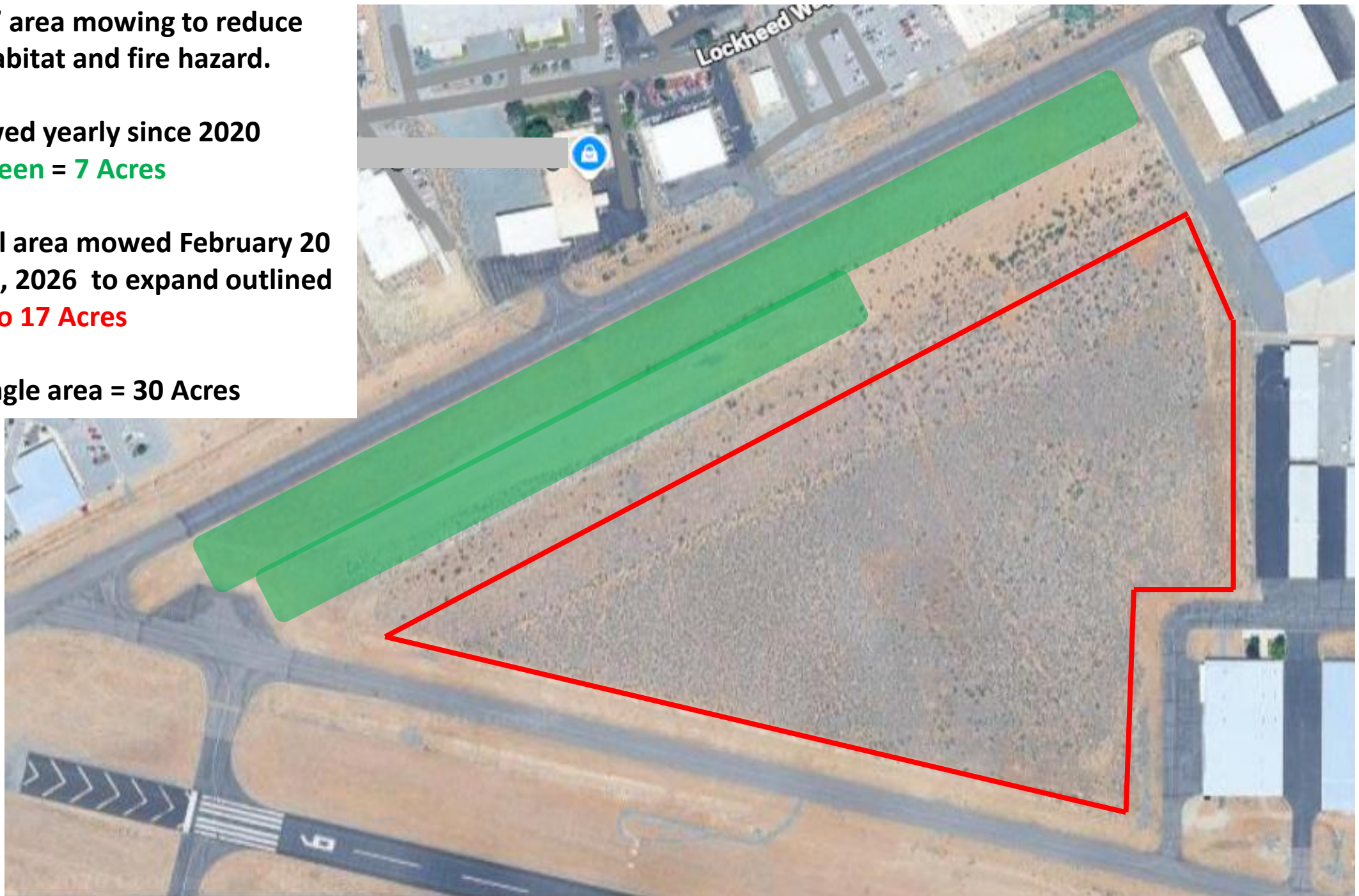

Large brush mowed in the area southwest of the quarry – March 9 – 12, 2026
2 acres



Balance Sheet Comparison

Carson City Airport Authority

As of February 28, 2026

DISTRIBUTION ACCOUNT	TOTAL	
	AS OF FEBRUARY 28, 2026	AS OF FEBRUARY 28, 2025 (PY)
Assets		
Current Assets		
Bank Accounts		
1075 LGIP-Deferred	445,204.77	435,643.09
1077 LGIP- General Fund	1,706,376.91	1,669,728.96
3099 Gen. Fund #1162	437,363.12	314,248.86
3199 Petty Cash	100.00	100.00
Total for Bank Accounts	\$2,589,044.80	\$2,419,720.91
Accounts Receivable		
2000 Accounts Receivable - Operating	245,140.95	223,980.94
Total for Accounts Receivable	\$245,140.95	\$223,980.94
Other Current Assets		
1499 Undeposited Funds	15,301.66	18,554.77
2001 AR offset	-1,331.00	-1,331.00
2010.1 Audit Adjustment to AR	0.00	0.00
2010 Due From Other Government	643.87	643.87
2011 Accrued Interest Receivable	9,031.37	9,031.37
2020 Grants Receivable-CY	0.00	0.00
2100 Prepaid Expenses	1,000.00	1,000.00
CTE Reimbursement Funds	0.00	-27,437.50
Grumman HU-16C Lien	0.00	0.00
Total for Other Current Assets	\$24,645.90	\$461.51
Total for Current Assets	\$2,858,831.65	\$2,644,163.36
Fixed Assets		
2120 land	0.00	146,542.03
2125 Machinery & Equipment	0.00	1,089,692.82
2126 Fencing	0.00	911,661.46
2130 Vehicle	0.00	1,033,779.35
2198 Accumulated Depreciation	0.00	-585,187.36
2201 Tractor	0.00	159,995.00
Total for Fixed Assets	\$0.00	\$2,756,483.30
Other Assets		
2300 Provided for LT Obligations	0.00	126,533.33
2305 NPV of Airport Leases	7,327,897.00	7,174,309.00
2810 Pension Requirement	0.00	196,462.04
Total for Other Assets	\$7,327,897.00	\$7,497,304.37
Total for Assets	\$10,186,728.65	\$12,897,951.03

Balance Sheet Comparison

Carson City Airport Authority

As of February 28, 2026

DISTRIBUTION ACCOUNT	TOTAL	
	AS OF FEBRUARY 28, 2026	AS OF FEBRUARY 28, 2025 (PY)
Liabilities and Equity		
Liabilities		
Current Liabilities		
Accounts Payable		
3000 Accounts Payable	228,916.70	51,154.76
Total for Accounts Payable	\$228,916.70	\$51,154.76
Credit Cards		
6321 Home Depot	591.28	344.14
6328 NSB Credit Card Rick 9053	1,028.80	1,049.75
6329 NSB CC Corey 9061	3,914.78	3,171.99
Total for Credit Cards	\$5,534.86	\$4,565.88
Other Current Liabilities		
2101 Payroll Liability	2,842.43	876.69
2102 Accrued Compensated Absences	0.00	8,619.28
2115 Accrued Expenses	0.00	21,000.00
3030 Audit Adj to AP	0.00	4,038.00
3090 Pension Requirement-Liab	0.00	71,068.00
3271 Current Portion of LTD	0.00	0.00
Total for Other Current Liabilities	\$2,842.43	\$105,601.97
Total for Current Liabilities	\$237,293.99	\$161,322.61
Long-term Liabilities		
3085 Net Pension Liability	0.00	336,955.00
3100 Leases Advances	0.00	0.00
3110 Deferred Inflows- Leases	6,553,911.00	6,610,616.00
3200 Mayes-Lease Transactions	26,797.50	159,570.83
3250 Gonzalez Deferred Lease	214,104.49	221,362.33
3260 Goni Deferred Lease	0.00	0.00
6325 Tractor US Bank	0.00	0.00
Total for Long-term Liabilities	\$6,794,812.99	\$7,328,504.16
Total for Liabilities	\$7,032,106.98	\$7,489,826.77
Equity		
4999 Retained Earnings	2,805,849.82	2,425,582.96
Net Income	-33,183.70	274,355.78
4200 Fund Balance	4,173,840.52	4,173,840.52
4999.1 GWFS to Fund FS adjustments	-3,791,884.97	-1,465,655.00
Total for Equity	\$3,154,621.67	\$5,408,124.26
Total for Liabilities and Equity	\$10,186,728.65	\$12,897,951.03

Carson City Airport Authority

Budget vs. Actuals Budget FY26

July 2025 - June 2026

	TOTAL			
	ACTUAL	BUDGET	OVER BUDGET	% OF BUDGET
Income				
5010 Real/Personal Property Tax				
5010.1 Aircraft	145,459.26	205,000.00	-59,540.74	70.96 %
5010.2 Building	119,012.13	145,000.00	-25,987.87	82.08 %
Total 5010 Real/Personal Property Tax	264,471.39	350,000.00	-85,528.61	75.56 %
5050 AIRPORT LEASES				
5050H Hanger Lease	55,080.00	73,000.00	-17,920.00	75.45 %
5051 Land Leases	251,534.82	320,000.00	-68,465.18	78.60 %
5052 Tower Leases	56,454.51	84,500.00	-28,045.49	66.81 %
5053 Lease-Mayes	4,680.00	6,240.00	-1,560.00	75.00 %
5054 Through The Fence		-1,742.00	1,742.00	
Total 5050 AIRPORT LEASES	367,749.33	481,998.00	-114,248.67	76.30 %
5150 Tie Down Fees	10,363.58	12,500.00	-2,136.42	82.91 %
5151 Gate Card Fees	3,252.88	1,500.00	1,752.88	216.86 %
5155 Parking Fees		500.00	-500.00	
5200 Committed-Fuel Flowage Fees	16,410.87	24,000.00	-7,589.13	68.38 %
5201 Committed-Jet Fuel Tax	2,078.45	3,000.00	-921.55	69.28 %
5250 Through the Fence Fees		9,750.00	-9,750.00	
5300 Class II FBO Fees	7,650.00	8,000.00	-350.00	95.63 %
5404 Rock Materials Sales	17,721.54	75,000.00	-57,278.46	23.63 %
5450 Reimbursements	0.00		0.00	
5500 Interest Income	16,295.95	800,000.00	-783,704.05	2.04 %
5915 Sales	-575.27		-575.27	
5998 Terminal Rental		400.00	-400.00	
Total Income	\$705,418.72	\$1,766,648.00	\$ - 1,061,229.28	39.93 %
GROSS PROFIT	\$705,418.72	\$1,766,648.00	\$ - 1,061,229.28	39.93 %
Expenses				
6169 Taxes & Licenses	84.40	300.00	-215.60	28.13 %
6268 Repairs & Maintenance	517.53		517.53	
6300 Operating Expenses				
6000 Airport Engineering				
6001 Engineering-General		3,000.00	-3,000.00	
Total 6000 Airport Engineering		3,000.00	-3,000.00	
6130 Dues	259.99	1,200.00	-940.01	21.67 %
6135 Memberships	250.00	250.00	0.00	100.00 %
6137 Conferences	2,055.00	2,500.00	-445.00	82.20 %
6170 SWAAAE BOD Travel	1,234.87	1,500.00	-265.13	82.32 %
6190 Office Expence-PC Software	505.86	800.00	-294.14	63.23 %
6200 Office Expenses -PC Hardware	664.14	1,250.00	-585.86	53.13 %
6211 Meals and Entertainment	903.91	2,200.00	-1,296.09	41.09 %

Carson City Airport Authority

Budget vs. Actuals Budget FY26

July 2025 - June 2026

	TOTAL			
	ACTUAL	BUDGET	OVER BUDGET	% OF BUDGET
6218 Marketing and Website	893.08	6,000.00	-5,106.92	14.88 %
6369 Travel	848.69	2,000.00	-1,151.31	42.43 %
Total 6300 Operating Expenses	7,615.54	20,700.00	-13,084.46	36.79 %
6301 Utilities				
6238 Stormwater Discharge Permit		1,000.00	-1,000.00	
6302 Phone & Internet	3,526.93	6,500.00	-2,973.07	54.26 %
6303 Electric	6,407.13	19,000.00	-12,592.87	33.72 %
6304 Gas	280.11	1,500.00	-1,219.89	18.67 %
6305 Water	1,702.24	2,500.00	-797.76	68.09 %
6306 Carson City Landfill	621.98	1,300.00	-678.02	47.84 %
Total 6301 Utilities	12,538.39	31,800.00	-19,261.61	39.43 %
6308 Office Expenses and Supplies	1,619.00	1,750.00	-131.00	92.51 %
6309 Legal	40,861.50	100,000.00	-59,138.50	40.86 %
6310 Security	2,364.92	6,400.00	-4,035.08	36.95 %
6311 CCAA printing		500.00	-500.00	
6312 Data Storage	600.00	500.00	100.00	120.00 %
6313 Insurance	6,674.00	15,000.00	-8,326.00	44.49 %
6314 Auditing	40,000.00	40,000.00	0.00	100.00 %
6314A Accounting/Bullis	17,084.00	25,000.00	-7,916.00	68.34 %
6315 Contract Services/Appraisals	4,840.08	7,000.00	-2,159.92	69.14 %
6316 Bank Charges/Square Chgs	754.29	1,000.00	-245.71	75.43 %
6317 Airport Equipment Maintenance	5,863.56	18,000.00	-12,136.44	32.58 %
6317.5 AWOS III Service Charges	6,914.00	7,000.00	-86.00	98.77 %
6318 Facility Maintenance	5,925.54	20,000.00	-14,074.46	29.63 %
6318.5 2025 Arrowhead Dr		20,000.00	-20,000.00	
Total 6318 Facility Maintenance	5,925.54	40,000.00	-34,074.46	14.81 %
6319 Airfield Maintenance	19,384.61	40,000.00	-20,615.39	48.46 %
6319.5 Gate Maintenance	1,232.41	2,000.00	-767.59	61.62 %
6319.51 Depreciation expense		140,000.00	-140,000.00	
6350 Labor Expense				
6351 Salaries	177,767.62	299,000.00	-121,232.38	59.45 %
6351.5 Overtime Budget (Airfield)	292.55	2,000.00	-1,707.45	14.63 %
6352 Healthcare	37,531.76	66,000.00	-28,468.24	56.87 %
6353 PERS Retirement Contribution	72,117.54	100,165.00	-28,047.46	72.00 %
6354 Nevada Payroll	1,048.75	1,500.00	-451.25	69.92 %
6355 Workers Compensation	3,569.78	8,360.00	-4,790.22	42.70 %
6356 State Unemployment Contri		2,950.00	-2,950.00	
6476 Uniforms	545.64	1,200.00	-654.36	45.47 %
Total 6350 Labor Expense	292,873.64	481,175.00	-188,301.36	60.87 %
6600 Bad Debt Transaction	149.95		149.95	
6999 Uncategorized Expense	1,600.00		1,600.00	
QuickBooks Payments Fees	795.64		795.64	

Carson City Airport Authority

Budget vs. Actuals Budget FY26

July 2025 - June 2026

	TOTAL			
	ACTUAL	BUDGET	OVER BUDGET	% OF BUDGET
Total Expenses	\$470,293.00	\$978,125.00	\$ - 507,832.00	48.08 %
NET OPERATING INCOME	\$235,125.72	\$788,523.00	\$ - 553,397.28	29.82 %
Other Income				
6051 AIP 48 - Forecasting Update				
6051.1 AIP 48 - Forecasting Update Revenue	26,902.10		26,902.10	
6051.2 AIP 48 - Forecasting Update Expense	-21,132.00		-21,132.00	
Total 6051 AIP 48 - Forecasting Update	5,770.10		5,770.10	
7000 Open House				
7001.2 Open House Expense Sept 2024	-555.25		-555.25	
7002.1 Open House Income Sept 2025	22,800.00	10,000.00	12,800.00	228.00 %
7002.2 Open House Expense Sept 2025	-23,691.05	-12,000.00	-11,691.05	197.43 %
7003.2 Open House Expenses June 2023	-178.66		-178.66	
Total 7000 Open House	-1,624.96	-2,000.00	375.04	81.25 %
8000 Discounts	149.71		149.71	
9999 Suspense	5,629.96		5,629.96	
FAA AIP Activity Revenue				
6048 AIP #46 Runway Drainage Project				
6048.1 AIP #46 Runway Drainage Project Income	100,225.00		100,225.00	
6048.2 AIP #46 Runway Drainage Project Expense	-112,196.00		-112,196.00	
Total 6048 AIP #46 Runway Drainage Project	-11,971.00		-11,971.00	
6049 AIP #47 Apron Rehab				
6049.1 AIP #47 Apron Rehab Revenue	19,073.63	150,000.00	-130,926.37	12.72 %
6049.2 AIP #47 Apron Rehab Expense	-22,072.50	-157,500.00	135,427.50	14.01 %
Total 6049 AIP #47 Apron Rehab	-2,998.87	-7,500.00	4,501.13	39.98 %
Total FAA AIP Activity Revenue	-14,969.87	-7,500.00	-7,469.87	199.60 %
FAA AIP Grant Revenue				
6036 AIP #37 Acquire Snow Removal Equipment				
6040.1 AIP 41 - Relocate AWOS Revenue	0.00		0.00	
6042 AIP #43 Approach Lighting System Phase 3 PAPI and MALSF				
6042.1 AIP #43 Approach Lighting System Phase 3 PAPI and MALSF Revenue	1,260.10	976,654.00	-975,393.90	0.13 %
6042.2 AIP #43 Approach Lighting System Phase 3 PAPI and MALSF Expense	-23,414.78	-1,000,000.00	976,585.22	2.34 %
Total 6042 AIP #43 Approach Lighting System Phase 3 PAPI and MALSF	-22,154.68	-23,346.00	1,191.32	94.90 %
6044 AIP #44 SRE Construct Auxiliary Building				
6044.1 6044 AIP #44 SRE Construct Auxiliary Building Revenue	1,176,199.72	419,890.00	756,309.72	280.12 %
6044.2 AIP #44 SRE Construct Auxiliary Building Expense	-	-343,746.00	-925,587.25	369.26 %
	1,269,333.25			
Total 6044 AIP #44 SRE Construct Auxiliary Building	-93,133.53	76,144.00	-169,277.53	-122.31 %
6046 AIP #45 Drainage Improvements Design (deleted)				

Carson City Airport Authority

Budget vs. Actuals Budget FY26

July 2025 - June 2026

	TOTAL			
	ACTUAL	BUDGET	OVER BUDGET	% OF BUDGET
6046.1 AIP #45 Drainage Improvements Design Revenue (deleted)		140,625.00	-140,625.00	
6046.2 AIP #45 Drainage Improvements Design Expense (deleted)		-150,000.00	150,000.00	
Total 6046 AIP #45 Drainage Improvements Design (deleted)		-9,375.00	9,375.00	
Total FAA AIP Grant Revenue	-115,288.21	43,423.00	-158,711.21	-265.50 %
Total Other Income	\$ -	\$33,923.00	\$ -	-354.72 %
	120,333.27		154,256.27	
Other Expenses				
6060 AIP 31- Master Plan Update				
6060.1 AIP 31- Master Plan Update Revenue		305,000.00	-305,000.00	
6060.2 AIP 31- Master Plan Update Expense		-320,250.00	320,250.00	
Total 6060 AIP 31- Master Plan Update		-15,250.00	15,250.00	
CCAA Funded Capital Projects				
6400 Capital Project				
6400.1 Paving		300,000.00	-300,000.00	
Total 6400 Capital Project		300,000.00	-300,000.00	
6417 Aggregate To Improve Safety Areas (500 ft Test Area)	1,734.38		1,734.38	
Total CCAA Funded Capital Projects	1,734.38	300,000.00	-298,265.62	0.58 %
Total Other Expenses	\$1,734.38	\$284,750.00	\$ -	0.61 %
			283,015.62	
NET OTHER INCOME	\$ -	\$ -250,827.00	\$128,759.35	48.67 %
	122,067.65			
NET INCOME	\$113,058.07	\$537,696.00	\$ -	21.03 %
			424,637.93	

Statement of Activity Comparison

Carson City Airport Authority

July 1, 2025-February 28, 2026

DISTRIBUTION ACCOUNT	TOTAL	
	JUL 1 2025 - FEB 28 2026	JUL 1 2024 - FEB 28 2025 (PY)
Income		
5010 Real/Personal Property Tax		
5010.1 Aircraft	129,297.12	127,588.72
5010.2 Building	105,788.56	104,390.72
Total for 5010 Real/Personal Property Tax	\$235,085.68	\$231,979.44
5050 AIRPORT LEASES		
5050H Hanger Lease	48,960.00	48,240.00
5051 Land Leases	221,758.43	179,876.03
5052 Tower Leases	50,147.68	48,779.00
5053 Lease-Mayes	4,160.00	4,160.00
Total for 5050 AIRPORT LEASES	\$325,026.11	\$281,055.03
5150 Tie Down Fees	9,124.46	7,027.87
5151 Gate Card Fees	3,252.88	2,891.67
5200 Committed-Fuel Flowage Fees	15,173.81	14,593.86
5201 Committed-Jet Fuel Tax	2,078.45	1,799.25
5300 Class II FBO Fees	3,600.00	3,600.00
5404 Rock Materials Sales	17,721.54	52,581.72
5450 Reimbursements	1,976.45	2,493.58
5500 Interest Income	16,295.95	69,017.63
5915 Sales	-575.27	0.10
Total for Income	\$628,760.06	\$667,040.15
Cost of Goods Sold		
Gross Profit	\$628,760.06	\$667,040.15
Expenses		
6169 Taxes & Licenses	84.40	
6268 Repairs & Maintenance	517.53	
6300 Operating Expenses		
6130 Dues	259.99	720.00
6135 Memberships	250.00	100.00
6137 Conferences	2,055.00	4,779.53
6170 SWAAAE BOD Travel	1,234.87	
6190 Office Expence-PC Software	505.86	371.34
6200 Office Expenses -PC Hardware	664.14	218.23
6211 Meals and Entertainment	903.91	576.56
6218 Marketing and Website	893.08	5,952.40
6369 Travel	848.69	272.43
6000 Airport Engineering		2,925.00
Total for 6300 Operating Expenses	\$7,615.54	\$15,915.49
6301 Utilities		
6302 Phone & Internet	3,491.93	4,473.50
6303 Electric	6,407.13	8,017.87
6304 Gas	280.11	526.73
6305 Water	1,702.24	1,989.15

Statement of Activity Comparison

Carson City Airport Authority

July 1, 2025-February 28, 2026

DISTRIBUTION ACCOUNT	TOTAL	
	JUL 1 2025 - FEB 28 2026	JUL 1 2024 - FEB 28 2025 (PY)
6306 Carson City Landfill	621.98	1,150.40
Total for 6301 Utilities	\$12,503.39	\$16,157.65
6308 Office Expenses and Supplies	1,619.00	1,190.60
6309 Legal	38,676.50	60,516.10
6310 Security	2,364.92	3,251.92
6312 Data Storage	530.00	403.53
6313 Insurance	1,272.00	11,797.08
6314A Accounting/Bullis	17,084.00	17,886.00
6314 Auditing	40,000.00	27,876.25
6315 Contract Services/Appraisals	4,840.08	10,500.00
6316 Bank Charges/Square Chgs	754.29	663.10
6317.5 AWOS III Service Charges	6,914.00	5,936.00
6317 Airport Equipment Maintenance	5,863.56	13,446.77
6318 Facility Maintenance	5,925.54	9,237.74
6319.5 Gate Maintenance	1,232.41	1,139.17
6319 Airfield Maintenance	19,384.61	20,710.95
6350 Labor Expense		
6351.5 Overtime Budget (Airfield)	292.55	
6351 Salaries	177,944.07	183,962.36
6352 Healthcare	37,531.76	43,300.26
6353 PERS Retirement Contribution	63,771.78	68,600.34
6354 Nevada Payroll	1,048.75	1,012.00
6355 Workers Compensation	3,569.78	4,061.87
6476 Uniforms	545.64	783.48
6363 Voya/Deferred Comp		630.00
Total for 6350 Labor Expense	\$284,704.33	\$302,350.31
6600 Bad Debt Transaction	149.95	1,181.27
6999 Uncategorized Expense	1,600.00	
QuickBooks Payments Fees	767.78	391.61
Total for Expenses	\$454,403.83	\$520,551.54
Net Operating Income	\$174,356.23	\$146,488.61
Other Income		
6051 AIP 48 - Forecasting Update		
6051.1 AIP 48 - Forecasting Update Revenue	26,902.10	
6051.2 AIP 48 - Forecasting Update Expense	-21,132.00	
Total for 6051 AIP 48 - Forecasting Update	\$5,770.10	
7000 Open House		
7001.2 Open House Expense Sept 2024	-555.25	-7,691.21
7002.1 Open House Income Sept 2025	22,800.00	
7002.2 Open House Expense Sept 2025	-23,691.05	-378.97

Statement of Activity Comparison

Carson City Airport Authority

July 1, 2025-February 28, 2026

DISTRIBUTION ACCOUNT	TOTAL	
	JUL 1 2025 - FEB 28 2026	JUL 1 2024 - FEB 28 2025 (PY)
7001.1 Open House Income Sept 2024		7,700.00
Total for 7000 Open House	-\$1,446.30	-\$370.18
8000 Discounts	149.71	9.94
9999 Suspense	5,629.96	-34,291.00
FAA AIP Activity Revenue		
6048 AIP #46 Runway Drainage Project		
6048.1 AIP #46 Runway Drainage Project Income	100,225.00	
6048.2 AIP #46 Runway Drainage Project Expense	-112,196.00	-3,500.00
Total for 6048 AIP #46 Runway Drainage Project	-\$11,971.00	-\$3,500.00
6049 AIP #47 Apron Rehab		
6049.1 AIP #47 Apron Rehab Revenue	19,073.63	
6049.2 AIP #47 Apron Rehab Expense	-21,597.50	
Total for 6049 AIP #47 Apron Rehab	-\$2,523.87	
Total for FAA AIP Activity Revenue	-\$14,494.87	-\$3,500.00
FAA AIP Grant Revenue		
6036 AIP #37 Acquire Snow Removal Equipment	\$0.00	\$196,453.76
6036.2 AIP #37 Acquire Snow Removal Equipment Expense		-211,368.09
Total for 6036 AIP #37 Acquire Snow Removal Equipment	\$0.00	-\$14,914.33
6040.1 AIP 41 - Relocate AWOS Revenue	0.00	19,722.00
6042 AIP #43 Approach Lighting System Phase 3 PAPI and MALSF		-\$5,727.00
6042.1 AIP #43 Approach Lighting System Phase 3 PAPI and MALSF Revenue	1,260.10	209,450.21
6042.2 AIP #43 Approach Lighting System Phase 3 PAPI and MALSF Expense	-23,414.78	-225,703.62
Total for 6042 AIP #43 Approach Lighting System Phase 3 PAPI and MALSF	-\$22,154.68	-\$21,980.41
6044 AIP #44 SRE Construct Auxiliary Building		
6044.1 6044 AIP #44 SRE Construct Auxiliary Building Revenue	1,090,073.78	-25,102.19
6044.2 AIP #44 SRE Construct Auxiliary Building Expense	-1,269,333.25	6,656.10
Total for 6044 AIP #44 SRE Construct Auxiliary Building	-\$179,259.47	-\$18,446.09
6035 AIP #36 Construct SRE Building		
6035.2 6035 AIP #36 Construct SRE Building Expense		-12,470.00

Statement of Activity Comparison

Carson City Airport Authority

July 1, 2025-February 28, 2026

DISTRIBUTION ACCOUNT	TOTAL	
	JUL 1 2025 - FEB 28 2026	JUL 1 2024 - FEB 28 2025 (PY)
Total for 6035 AIP #36 Construct SRE Building		-\$12,470.00
6037 AIP #38 Install Approach Lighting Phase I		25,796.00
Total for FAA AIP Grant Revenue	-\$201,414.15	-\$22,292.83
6041.1 AIP #42 Approach Lighting System Phase 2 PAPI and MALSF Rev		36,618.00
Total for Other Income	-\$205,805.55	-\$23,826.07
Other Expenses		
CCAA Funded Capital Projects		
6417 Aggregate To Improve Safety Areas (500 ft Test Area)	1,734.38	
6414 Terminal Building Architectural Renderings		32,161.65
Total for CCAA Funded Capital Projects	\$1,734.38	\$32,161.65
6020 CCAA Funded Capital Project – FAA Engineering and Construction		19,780.20
6099 Contra expense for FAA grant for Carson City asset		-203,635.09
Total for Other Expenses	\$1,734.38	-\$151,693.24
Net Other Income	-\$207,539.93	\$127,867.17
Net Income	-\$33,183.70	\$274,355.78